

# H0514-MP2

f=5mm F1.4  
for 1/2 type Megapixel Cameras  
C-Mount

Model No.	H0514-MP2		Effective	Front	φ 27.8mm
Focal Length	5mm		Lens Aperture	Rear	φ 14.8mm
Max. Aperture Ratio	1:1.4		Distortion	1/2type	-0.48%(y=4.0)
Max. Image Format	6.4mm x 4.8mm(φ 8mm)			1/3type	-2.26%(y=3.0)
Operation Range	Iris	F1.4 - 16C	Back Focal Length	10.8mm	
	Focus	0.1m - 0.9m	Flange Back Length	17.526mm	
Control	Iris	Manual	Mount	C-Mount	
	Focus	Manual	Filter Size	M43 P=0.75mm	
Object Dimension at M.O.D	1/2type	15.0cm x 11.1cm	Dimensions	φ 44.5mm x 45.5mm	
	1/3type	11.1cm x 8.3cm	Weight	102g	
Angle of View	D	1/2 type	1/3 type	62.3°	
	H			51.4°	
	V			39.5°	
Operating Temperature	-10°C - +50°C				

M.O.D : Minimum Object Distance

**Dimensions**

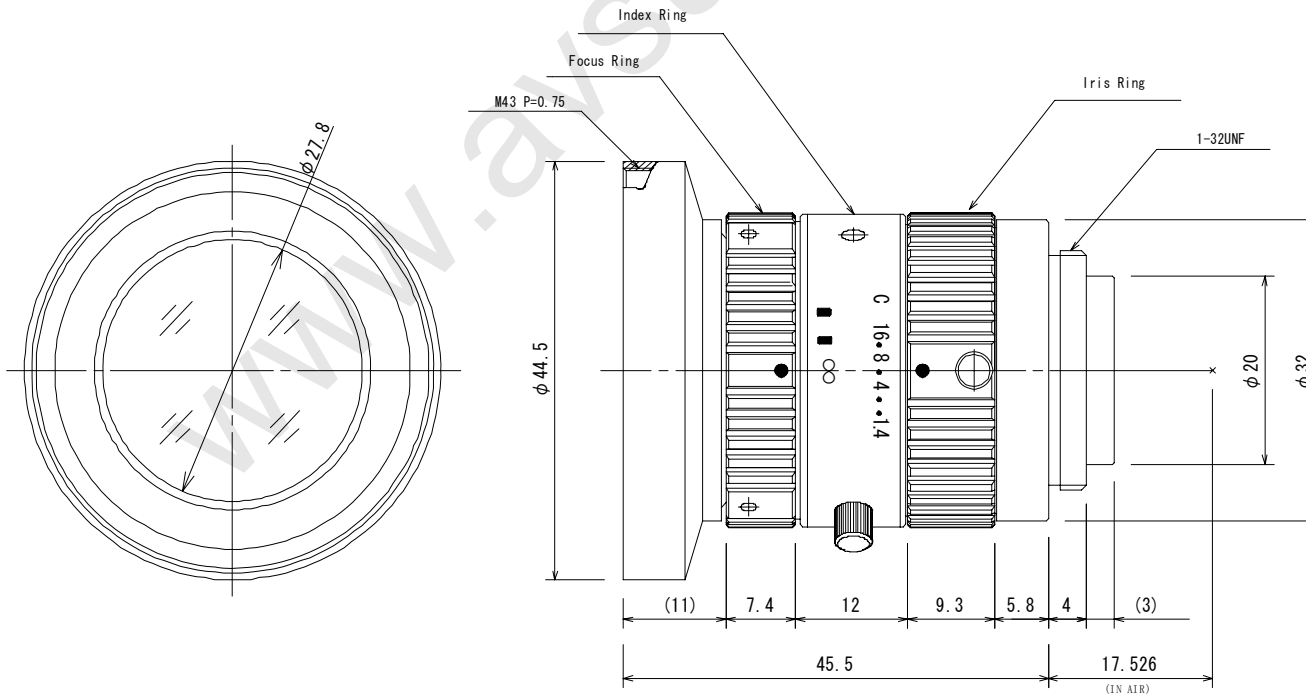

Distributed By: Audio Video Supply -- Tel: 1-800-284-2288 -- www.avsupply.com

Specification is subject to change without any notice.

For design help, accessories or pricing, please contact:  
sales@avsupply or call: 1-858-565-1101

**AUDIOVIDEO SUPPLY**  
1-800-284-2288 sales@avsupply.com  
www.avsupply.com