

# H3Z1014CS

**3X 10mm - 30mm F1.4**  
**for 1/2 type Cameras, Vari-focal Manual Iris**  
**CS-Mount**

Model No.		H3Z1014CS		Effective	Front	Ø26.6mm	
Focal Length		10mm - 30mm		Lens Aperture	Rear	Ø9.0mm	
Max. Aperture Ratio		1:1.4		Back Focal Length	Tele	9.8mm	
Max. Image Format		6.4mm x 4.8mm(Ø8mm)			Wide	11mm	
Operation Range	Iris	F1.4 - F16C		Flange Back Length		12.5mm	
	Focus	0.6m - Inf.		Mount		CS-Mount	
	Zoom	10mm - 30mm		Filter Size		M37.5 P=0.5mm	
Control	Iris	Manual		Dimensions		Ø47mm x 57.7mm	
	Focus	Manual		Weight		125g	
	Zoom	Manual					
Object Dimension at M.O.D.	10mm	38.8cm x 28.6cm					
	30mm	13.1cm x 9.9cm					
Angle of View	D	1/2 type	44.8° - 15.6°	1/3 type	35.6° - 11.7°	1/4 type	25.1° - 8.8°
	H		35.8° - 12.5°		26.8° - 9.4°		20.1° - 7.0°
	V		26.8° - 9.4°		20.1° - 7.1°		15.0° - 5.3°
Operating Temperature		-20°C - +50°C					

M.O.D. : Minimum Object Distance

## Dimensions

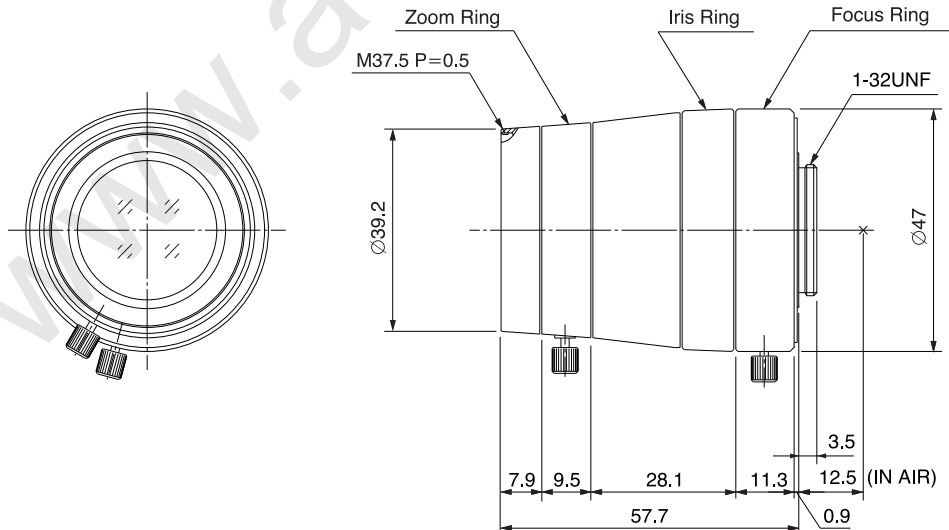

Specifications subject to change without notice.

For design help, accessories or pricing, please contact:  
 sales@avsupply or call: 1-858-565-1101