

STX-1700XPW

SmarTouch™ 2-Way Spread Spectrum Wireless Touchpanel w/Wall Mount

The STX-1700XPW is a stylish and compact 2-way wireless touchpanel featuring a brilliant 5.7" active matrix touchscreen, optional pushbuttons and in-wall docking station. Long-range spread spectrum RF and Isys color graphics combine to deliver outstanding touchpanel performance with the added combination of portable wireless and wired wall mount versatility.

SmarTouch

A SmarTouch touchpanel offers an ideal user-interface for controlling home theater, boardroom AV and a host of other applications, providing a wide-open canvas for the creation of custom control screens tailored to the user's unique needs and tastes. Incredibly compact and portable, the SmarTouch touchpanel does away with piles of remotes, cryptic control panels and cluttered wall switches, affording true "one-touch" control over a broad range of complex devices and systems.

2-Way Spread Spectrum RF Wireless

Crestron's 2.4 GHz spread spectrum RF technology provides reliable long-range wireless operation up to 150 feet indoors using a single TPS-RFGWX RF gateway (sold separately). Bidirectional communication supports true-feedback and dynamic text capability to enable display of all kinds of data - from system power status and audio settings to digital media playlists, satellite radio program guides, alert messages, room temperature, lighting levels, and much more.

Extended bandwidth makes the STX-1700XPW ideal for applications employing large amounts of dynamic text or multiple wireless touchpanels. "WiFi friendly" technology permits selection from 10 possible bands within the 2.4 GHz spectrum to prevent interference with 802.11 devices and other non-Crestron RF equipment.

Isys®

The powerful Isys engine produces astonishing 16-bit full-color graphics with lightning-fast performance and incredible versatility. The 32-bit Freescale ColdFire® microprocessor combines with an ingenious and ultra efficient operating system to support high-resolution graphics and images, dynamic text, animations, multimode objects, subpages, and more.

Synapse™

Crestron's exclusive Synapse Image Rendering Algorithm enables system programmers to produce amazing graphics - faster and easier. Advanced antialiasing delivers crisper, sharper objects and text. Enhanced 3D effects add new depth and style. And because Synapse is native to the touchpanel, memory requirements and upload time are substantially reduced.

Quick-Touch Pushbuttons

The STX-1700XPW includes a button bezel kit which may be installed to provide ten tactile pushbuttons for quick-touch access to frequently used commands. In standby, the pushbuttons may be operated without waking the touchscreen for extended battery life. Custom engraving of the pushbuttons may be attained using Crestron Engraver software.

Long-Life NiMH Batteries

A fast-charging NiMH battery pack is included to provide long-lasting wireless operation, with adjustable power management built in to preserve battery life up to 20 hours in standby.

In-Wall Docking Station

When docked, the STX-1700XPW operates as a wired touchpanel with a



direct connection to the Cresnet network. The docking assembly also provides operating power to the touchpanel while simultaneously charging the battery pack. A software-controlled latch secures the touchpanel when docked and is released upon pressing a button or entering a code on the touchpanel. When released, the STX-1700XPW switches automatically to wireless operation.

The STX-1700XPW ships complete with docking assembly and back box. The backbox includes knockouts to accommodate conduit fittings and is suitable for both pre- and post-construction installation.

- > "WiFi Friendly" 2-way Spread Spectrum RF wireless
- > 5.7" active matrix touchscreen display | 320 x 240 resolution
- > Isys Graphics Engine | Synapse Image Rendering Algorithm
- > 10 quick-touch pushbuttons (optional) | audible "key click"
- > Long-lasting NiMH batteries | in-wall docking station/charger
- > Lightweight contoured design for tabletop and handheld use

SPECIFICATIONS

Touchscreen Display

Display Type: TFT Active matrix color LCD
Size: 5.7 inch (14.5 cm) diagonal
Aspect Ratio: 4:3 QVGA
Resolution: 320 x 240 pixels
Color Depth: 16-bit, 64k colors
Illumination: Backlit fluorescent
Viewing Angle: ±65° horizontal, +65°/-40° vertical
Touchscreen: Resistive membrane

Buttons

(10) Replaceable engravable buttons, programmable;
Requires installation of button bezel kit (included)

STX-1700XPW

Wireless

RF Transceiver: "Wi-Fi friendly" 2.4 GHz spread spectrum 2-way RF (2400 to 2483 MHz)

Range: 3 to 150 feet min/max indoor, 1000 feet outdoor
TPS-RFGWX RF Gateway required (maximum 15 touchpanels per gateway)

Processor

CPU: 32-bit Freescale ColdFire® Microprocessor

Memory

DRAM: 8 MB

Flash: 4 MB

Maximum Project Size: 3 MB

Graphic Engine

Isys engine, 16-bit non-palette graphics; 65,536 colors; Synapse image rendering algorithm; multi-mode objects; animation

Audio

Built-in transducer for "key click" sound

Connectors

Power: (1) 2.5mm barrel DC power jack;

12 Volt DC power input (PW-1215 power supply sold separately)

Cresnet Upload: (1) 3.5 mm mini TRS phone jack;

Connects to Cresnet control network while uploading only

Battery

Model/Type: ST-BTPN battery pack, NiMH, 4.8 Volt, 4100 mAh

Usage per Charge: ~3 hours continuous use at full brightness, 20 hours in standby

Charging Time: 2.7 to 6 hours (depending upon use while charging)

Power Requirements

Touchpanel: 18 Watts (1.5 Amps) @ 12 Volts DC;

(PW-1215 power supply sold separately)

Docking Assembly (DA-1700CW included) : 34 Watts Cresnet Power Usage (1.42 Amps @ 24 Volts DC)

Environmental

Temperature: 50° to 113°F (10° to 45°C)

Humidity: 10% to 90% RH (non-condensing)

Enclosure

Construction: High impact black/silver injection-molded case with metal docking plate

Dimensions

Height: 3.85 in (9.78 cm)

Width: 8.75 in (22.23 cm)

Depth: 5.51 in (14.00 cm)

Weight

1.85 lbs (0.84 kg) - not including battery or docking assembly

Available Models

STX-1700XPW: SmarTouch™ 2-Way 2.4 GHz Spread Spectrum RF Wireless 5.7" Active Matrix Color Touchpanel with Wall Mount Docking Station. [Limited Supply]

Included Accessories

1700C-BTNB-BEZELS Button Bezel Kit with Black Buttons (blank) [Included Quantity: 1]

BB-1700CW Back Box [Included Quantity: 1]

DA-1700CW Docking Assembly [Included Quantity: 1]

ST-BTPN Battery Pack for SmarTouch 1550 and 1700 wireless model touchpanels [Included Quantity: 1]

Available Accessories

1700C-BTNB: Engravable Button Caps, Black

1700C-BTNS: Engravable Button Caps, Silver

ST-PK: Programming Cable Kit

TPS-RFGWX: 2.4 GHz Spread Spectrum 2-Way RF Gateway [Limited Supply]

STX-1700CPW

Front

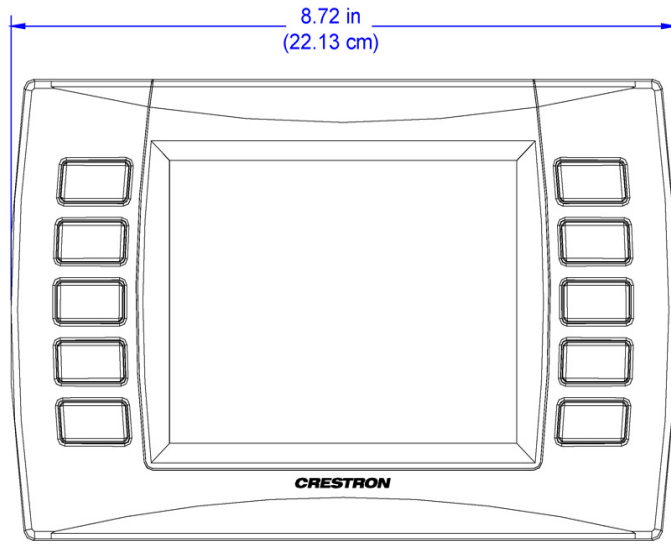

NOTE: Shown with optional engravable pushbuttons

Top

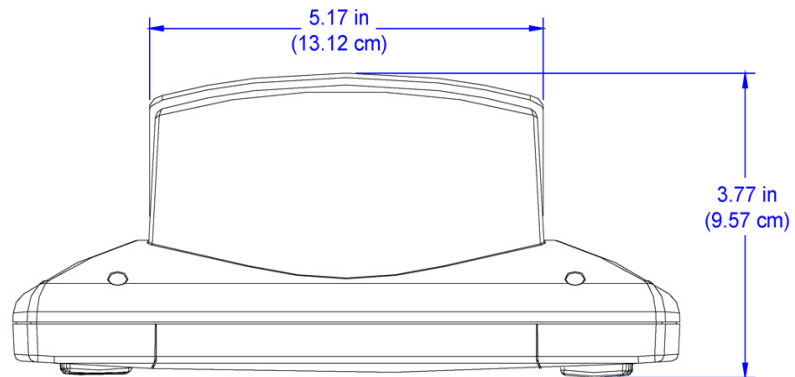

Sides

