

Docking Station/Charger for WPR-48

The WPR-DS is a docking station and battery charger designed specifically for use with the **WPR-48** Waterproof Handheld Remote. One (1) WPR-DS is included with each WPR-48.

SPECIFICATIONS

Connectors

PC: (1) 6-pin RJ-11 female;
12VDC: (1) 2.5mm barrel DC power jack;

Indicators

Power (Logo): (1) green LED, indicates power supplied from power pack
CHG: (1) red LED, indicates battery charging status
RDY: (1) green LED, indicates battery is fully charged

Power Requirements

Power Pack: 0.5 Amp @ 12 Volts DC;
120 Volts AC, 60 Hz power pack, model [PW-1205](#)

Enclosure

High impact blue injection-molded plastic case

Environmental

Temperature: 32° to 140° F (0° to 60° C)
Humidity: 0% to 100% RH (non condensing)

Dimensions

Height: 1.27 in (33 mm)
Width: 3.29 in (84 mm)
Depth: 5.08 in (129 mm)

Weight

8.3 oz (230 g)

INTERNATIONAL VERSION (230 VAC)

WPRI-DS



All the features and specifications of the WPR-DS except:
Power Requirements
Power Pack: 0.5 Amp @ 12 Volts DC;
230 Volts AC, 50 Hz power pack, model [PWI-1215](#)

ACCESSORIES

PW-1205:

Notes:

Crestron is a trademark of Crestron Electronics, Inc. Other trademarks and trade names may be used in this document to refer to either the entities claiming the marks and names or their products. Crestron disclaims proprietary interest in the marks and names of others.

Docking Station/Charger for WPR-48

Top

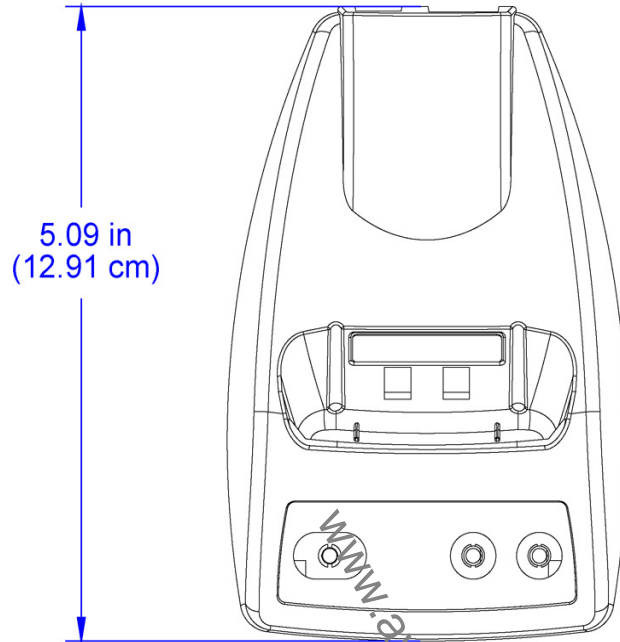

Back

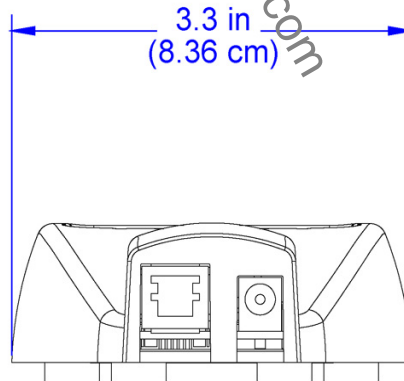

Side

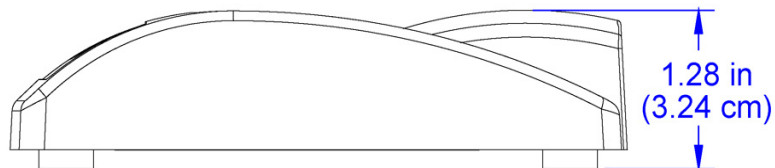

WPR-DS

Docking Station/Charger for WPR-48

Top

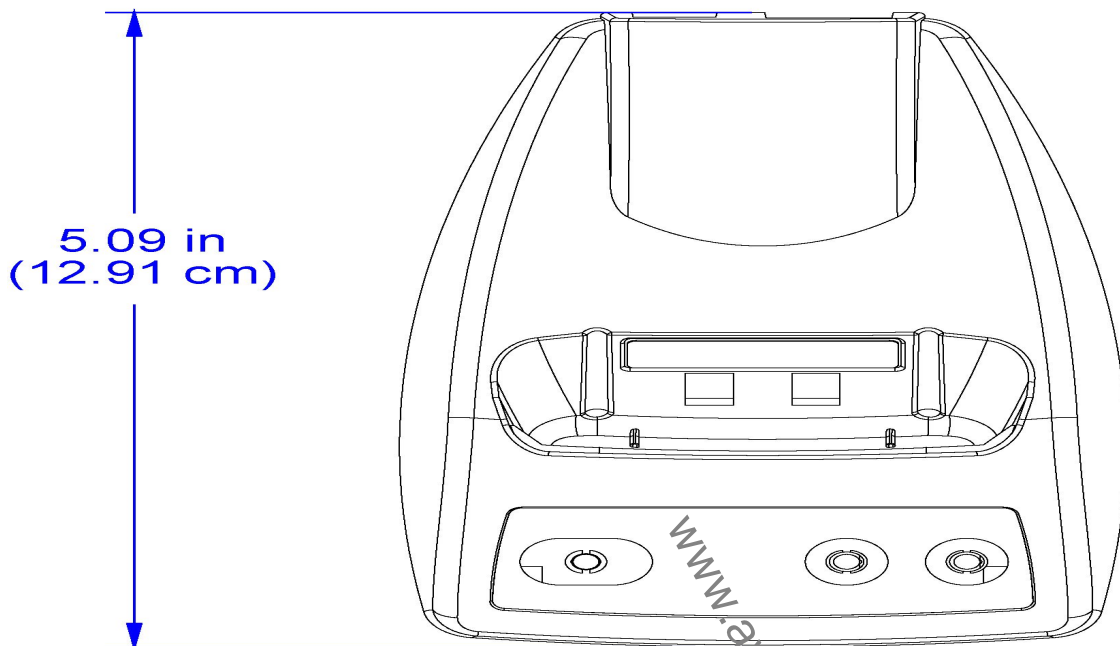

Back

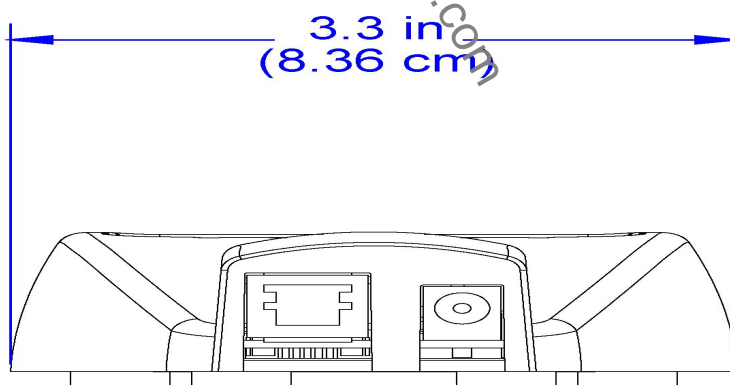

Side

