

PT112N/PT112N-XT

Vandal Resistant **12x** PTZ Dome

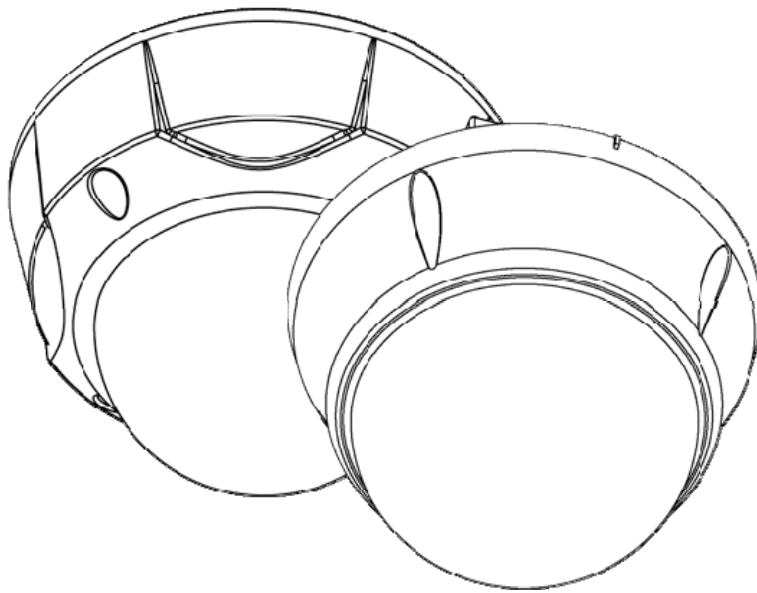

User Manual

CBC (AMERICA) Corp.

NY: 55 Mall Drive • Commack, NY 11725 (800) 422-6707
CA: 21241 S. Western Ave, Suite 160 • Torrance, CA 90503
(877) 407-9555
www.computarganz.com



① Introduction	
Features	3
Product & Accessories	5
Parts Name & Functions	7
② Installation	
DIP Switch Setup	8
Installation using Ceiling Mount Bracket	11
Installation using Wall Mount Bracket	12
Installation using Flush Mount Bracket	13
Cabling	14
③ Operation	
Check Points before Operation	17
Preset and Pattern Function Pre-Check	17
Starting OSD Menu	18
Reserved Preset	18
Preset	19
Swing	19
Pattern	20
Group	21
Other Functions	22
OSD Display of Main Screen	23
④ How to use OSD Menu	
General Rules of Key Operation for Menu	24
Main Menu	24
Display Setup	25
Privacy Zone Mask Setup	26
Camera Setup	27
Motion Setup	30
Preset Setup	32
Swing Setup	33
Pattern Setup	34
Group Setup	35
System Initialize	37
⑤ Specifications	38
Dimensions	39



Features

❑ Camera Specifications

- CCD Sensor : 1/4" Super-HAD CCD
- Zoom Magnification : × 12 Optical Zoom, × 12 Digital Zoom (Max × 144 Zoom)
- Day & Night Function
- Variable Focus Mode: Auto-Focus / Manual Focus / Semi-Auto Focus.
- Independent & Simultaneous Camera Characteristic Setup in Preset operation

❑ Advanced Pan/Tilt Functions

- Max. 360°/sec high speed Pan/Tilt Motion
- Using Vector Drive Technology, Pan/Tilt motions are accomplished with the shortest path. As a result, time to target view is reduced dramatically and the video stream transfers are natural to watch.
- For jog operation using a controller, an ultra slow speed of 0.05°/sec can be reached, making it very easy to relocate camera to the desired target view. Additionally, it is easy to move the camera to a desired position with zoom-proportional pan/tilt movement.

❑ Preset, Pattern, Swing, Group, Privacy Mask and More...

- Max. 127 Presets are assignable and characteristics of each preset can be set up independently, such as White Balance, Auto Exposure, Label and so on.
- Max. 8 set of Swing actions can be stored. This enables camera to move automatically between two preset positions at a designated speed.
- Max. 4 Patterns can be recorded and played back. This enables camera to automatically follow any trajectory preset by joystick as closely as possible.
- Max. 8 set of Group action can be stored. This enables camera to move automatically with a combination of Preset or Pattern or Swing. A Group is composed of max. 20 entities of Preset/Pattern/Swings.
- Privacy Masks are assignable, so as not to intrude on other's privacy. (8 Privacy Zones)

❑ PTZ (Pan/Tilt/Zoom) Control

- With RS-485 communication, max. of 255 cameras can be controlled at the same time.
- Pelco-D or Pelco-P protocol can be selected as a control protocol in the current firmware version.



❑ **OSD (On Screen Display) Menu**

- OSD menu is provided to display the status of camera and to configure the functions interactively.
- The information such as Camera ID, Pan/Tilt Angle, Alarm Input and Preset can be displayed on screen.

❑ **Alarm I/O Functions**

- 4 alarm sensor Inputs are available.
- To completely eliminate external electric noise and shock, alarm sensor Input is decoupled from photo coupler.
- If an external sensor is activated, camera can be set to move to the corresponding Preset position.

❑ **Reserved Presets for Special Purpose**

- Most camera characteristics can be set up easily and directly with reserved preset, without entering the OSD menu. For more information, refer to “Reserved Preset” in this manual.

❑ **IP66 (weather resistant) **(PT112N-XT model only)***

- This product has been certified to the IP66 standard for waterproof and spray proof environments. Also for the same reason it can be protected from dust and rainstorms.

Product & Accessories

☐ Product & Accessories- **PT112N-XT model (outdoor).**

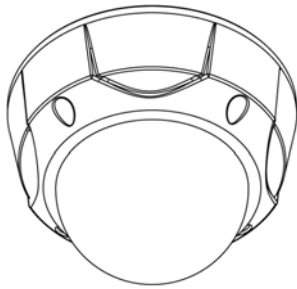

● Main Body

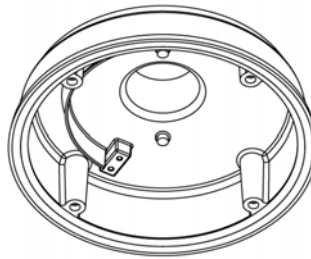

● Mount Adapter

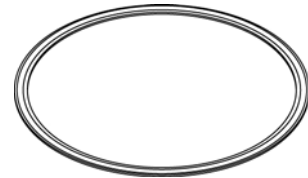

● Gasket(Rubber)

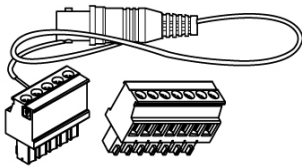

● Terminal Block
Video cable

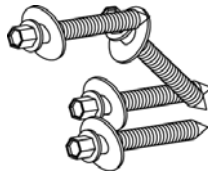

● Screws

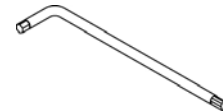

● Six angles wrench

☐ Options

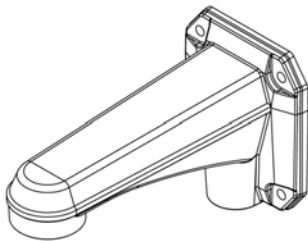

● Wall Mount Bracket

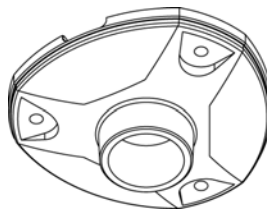

● Ceiling Mount Bracket

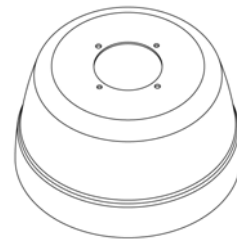

● Sun shield

❑ Product & Accessories- **PT112N model (indoor).**

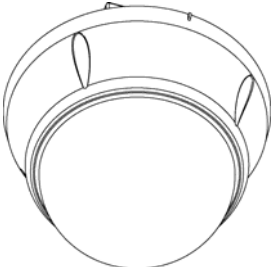

● Main Body

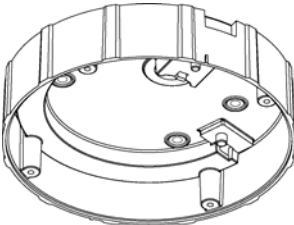

● Surface Mount Bracket

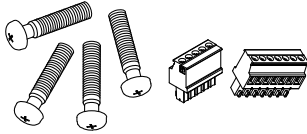

● Screws & Terminal Block

❑ Options

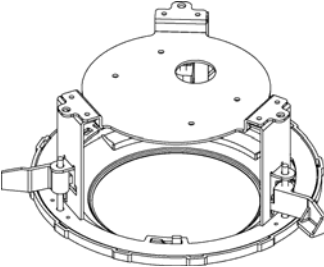

● In-Ceiling Mount Bracket

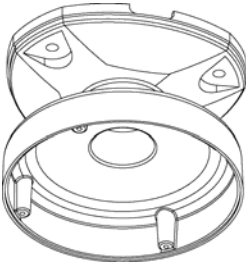

● Ceiling Mount Bracket

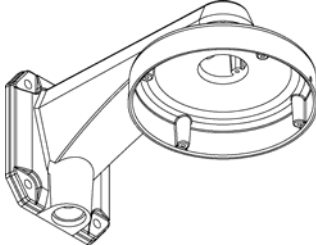

● Wall Mount Bracket

Parts Name & Functions

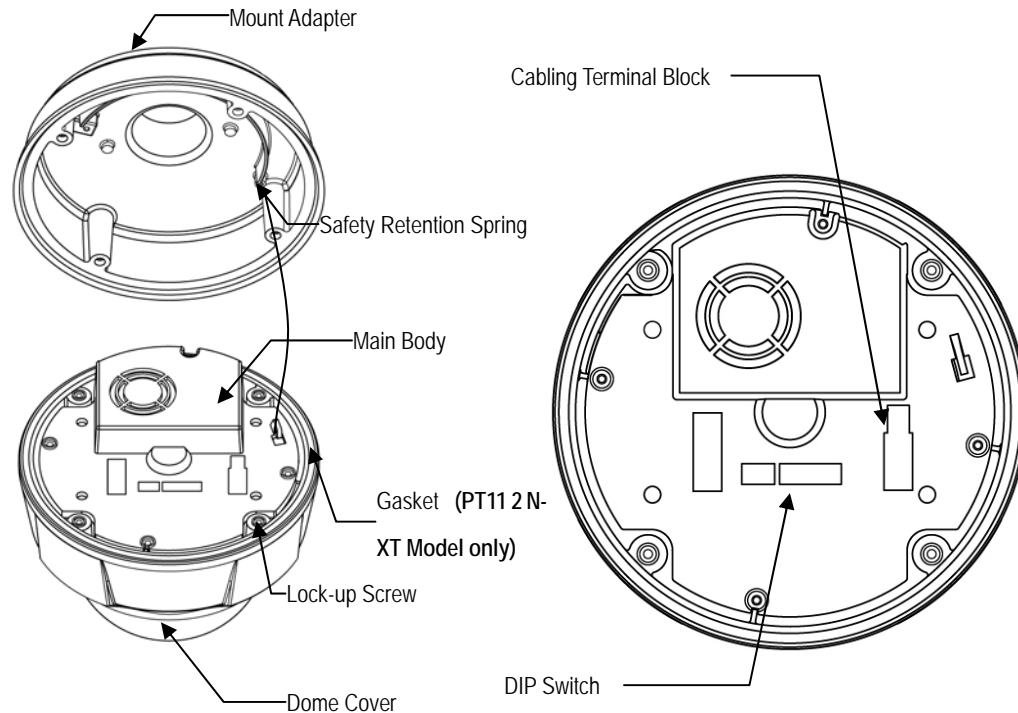

Main Unit / Surface Mount Bracket

- Dome Cover
- Surface Mount Bracket
- Gasket (**PT112N-XT model only**)
- Lockup Screw
- Cabling Terminal Block
- DIP Switch
- Fall-proof spring

Do not remove protective vinyl from dome cover before finishing all installation processes to protect dome cover from scratches or dust.

The surface mount bracket is used for installing either a ceiling mount or wall mount bracket. Separate the cover first and then attach it directly to ceiling. Camera must be assembled at the last stage.

Protect it from dust and rainstorm. Move projecting part of the gasket which should be placed on the low to main body position

Fixes main unit to surface mount bracket.

During installation, Power, Video, Communication, Alarm Input cables are connected on to this cabling terminal block. Pull out from Surface Mount Bracket and connect to Main Body hook.

Adjusts camera ID and protocols.

After installing fall-proof spring on Bracket , hang on the safety ring to protect the camera from falling

Back of Main Unit

DIP Switch Setup

Before you install the camera, you should set the DIP switches to configure the camera ID and communication protocol.

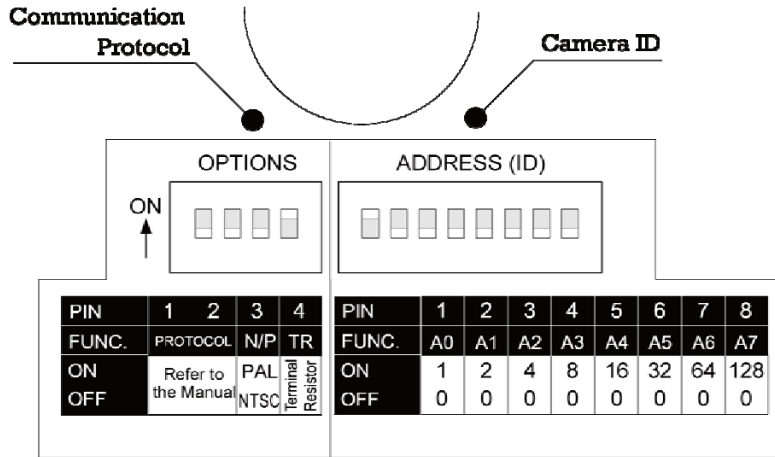

Camera ID Setup

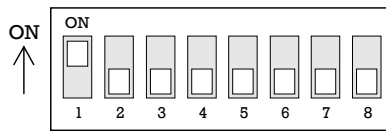

- The ID number of camera is set using a binary number. Examples shown below.
- The range of ID is 1~255. **Do not use 0 as camera ID.** Factory default of Camera ID is 1.
- If you want to control a certain camera, you must match the camera ID with Cam ID setting of DVR or Controller.

Pin	1	2	3	4	5	6	7	8
ID	1	2	4	8	16	32	64	128
1	on	off	off	off	off	off	off	off
2	off	on	off	off	off	off	off	off
3	on	on	off	off	off	off	off	off
4	off	off	on	off	off	off	off	off
5	on	off	on	off	off	off	off	off
6	off	on	on	off	off	off	off	off
7	on	on	on	off	off	off	off	off
8	off	off	off	on	off	off	off	off
9	on	off	off	on	off	off	off	off
10	off	on	off	on	off	off	off	off

Pin	1	2	3	4	5	6	7	8
ID	1	2	4	8	16	32	64	128
11	on	on	off	on	off	off	off	off
12	off	off	on	on	off	off	off	off
13	on	off	on	on	off	off	off	off
14	off	on	on	on	off	off	off	off
15	on	on	on	on	off	off	off	Off
16	off	off	off	off	on	off	off	off
17	on	off	off	off	on	off	off	off
18	off	on	off	off	on	off	off	off
19	on	on	off	Off	on	off	off	off
20	off	off	on	off	on	off	off	off

Pin	1	2	3	4	5	6	7	8
ID	1	2	4	8	16	32	64	128
21	on	off	on	off	on	off	off	off
22	off	on	on	off	on	off	off	off
23	on	on	on	off	on	off	off	off
24	off	off	off	on	on	off	off	off
25	on	off	off	on	on	off	off	off
26	off	on	off	on	on	off	off	off
27	on	on	off	on	on	off	off	off
28	off	off	on	on	on	off	off	off
29	on	off	on	on	on	off	off	off
30	off	on	on	on	on	off	off	off

Pin	1	2	3	4	5	6	7	8
ID	1	2	4	8	16	32	64	128
31	on	on	on	on	on	off	off	off
32	off	off	off	off	off	on	off	off
33	on	off	off	off	off	on	off	off
34	off	on	off	off	off	on	off	off
35	on	on	off	off	off	on	off	Off
36	off	off	on	off	Off	on	off	off
37	on	off	on	off	Off	on	off	off
38	off	on	on	off	Off	on	off	off
39	on	on	on	off	Off	on	off	off
40	off	off	off	on	Off	on	off	off

❑ Communication Protocol Setup

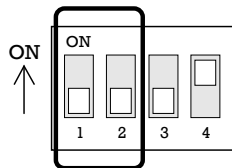

- Select the appropriate Protocol with DIP switch combination.

Switch State		Protocol
P0 (Pin 1)	P1 (Pin 2)	
OFF	OFF	PELCO-D, 2400 bps
ON	OFF	PELCO-D, 9600 bps
OFF	ON	PELCO-P, 4800 bps
ON	ON	PELCO-P, 9600 bps

- If you want to control using DVR or P/T controller, their protocol must be identical to camera. Otherwise, you **cannot** control the camera.
- If you changed camera protocol by changing DIP S/W, the change will be effective after you reboot the camera.
- Factory default of protocol is “Pelco-D, 2400 bps”.

❑ Reserved for Supplier

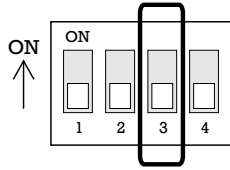

- Pin 3 is only for supplier, DO NOT CHANGE THESE ITS ORIGINAL STATE. If you change one of these, proper operation can not be achieved.

⊙ Pin 3 PAL / NTSC system selection of Camera. DO NOT CHANGE THIS PIN.

☐ Terminal Resistor Setup

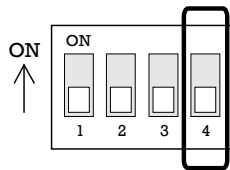

Terminal resistor is used if your system meets one of following two conditional cases.

- **Case1: Control cable between camera and controller is relatively long (1:1 connection)**

If communication cable is very long, the electrical signal will bind in the terminal point. This reflected signal causes signal distortion, resulting in a degradation of camera function. In this case, the terminal resistor of both sides (i.e. camera and controller) must be set to the 'ON' state.

- **Case2: Multiple cameras are controlled at the same time**

Due to similar reasons stated in case 1, the terminal resistors of the controller and the last camera must be set to 'ON' state. The camera with the longest cable length is determined to be the 'last' camera. Do not turn on the terminal resistor of all cameras.

Keyboard Controller / DVR

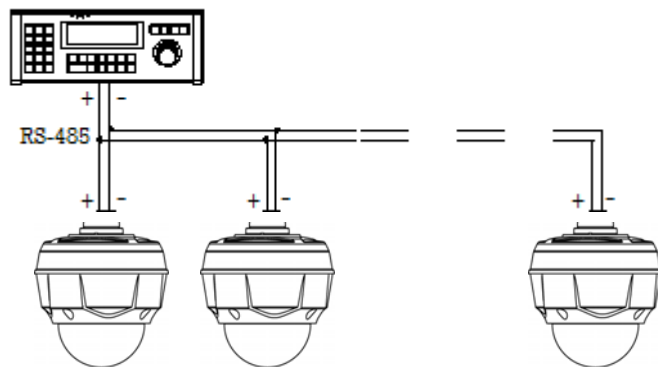

Installation using Ceiling Mount Bracket

- After putting the Gasket on the ceiling
Fasten ceiling mount bracket to ceiling with 3 screws.
- ② Wire cables to terminals and connect the terminals to main unit. **Do not use surface mount bracket!**

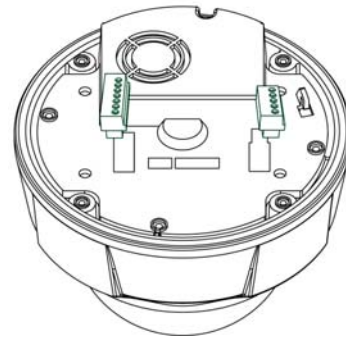
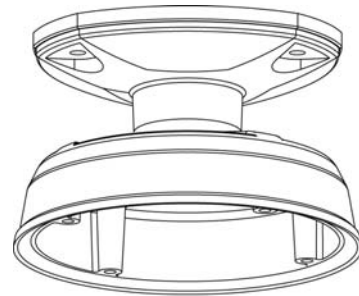
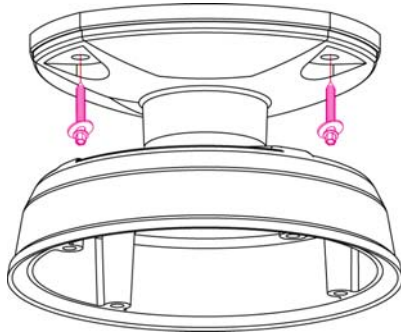

- ① Hang the camera on the safety ring and assemble it using the fall-proof spring.
- ② Remove protective vinyl from dome cover.

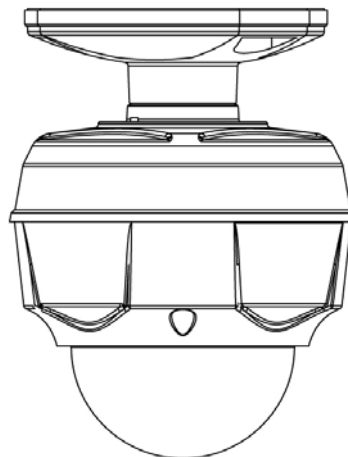
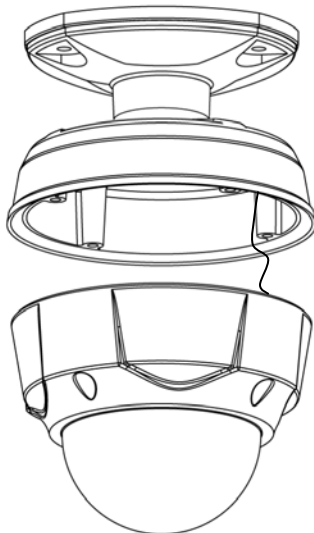



Installation using Wall Mount Bracket

- ① After putting the Gasket on the wall
Fasten wall mount bracket to ceiling with 4
screws.

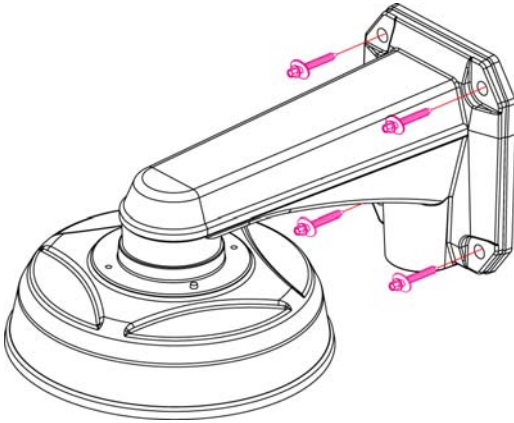

- ② Wire cables to terminals and connect the
terminals to main unit. **Do not use surface
mount bracket!**

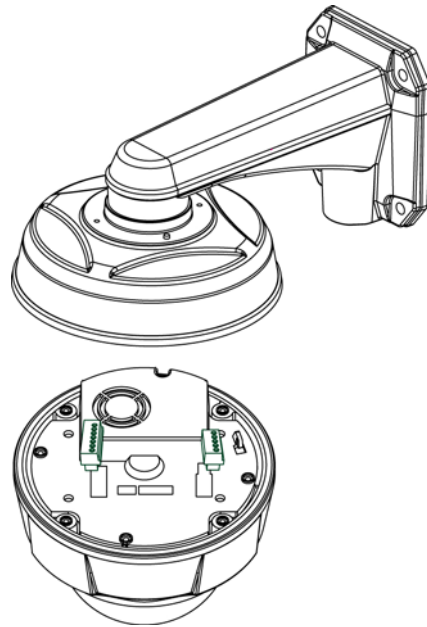

- ③ Fasten main unit to wall mount bracket with 4
screws.
- ④ Remove protective vinyl from dome cover.

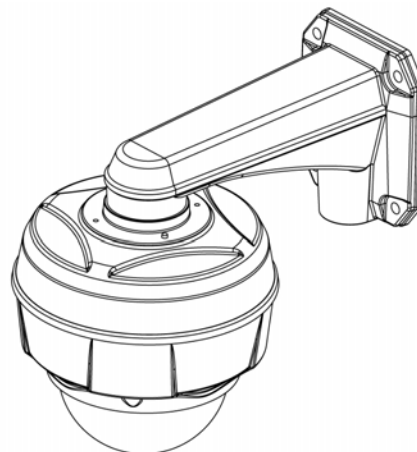
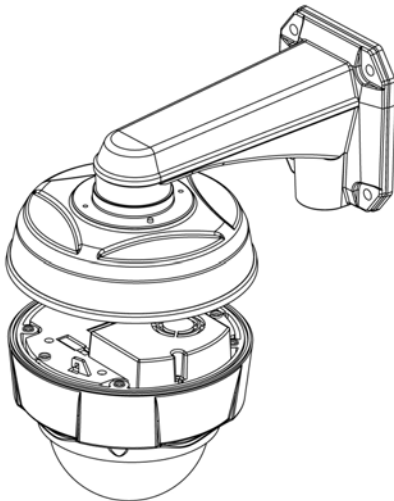

Installation using Flush Mount Bracket

- Cut 3 holes in ceiling

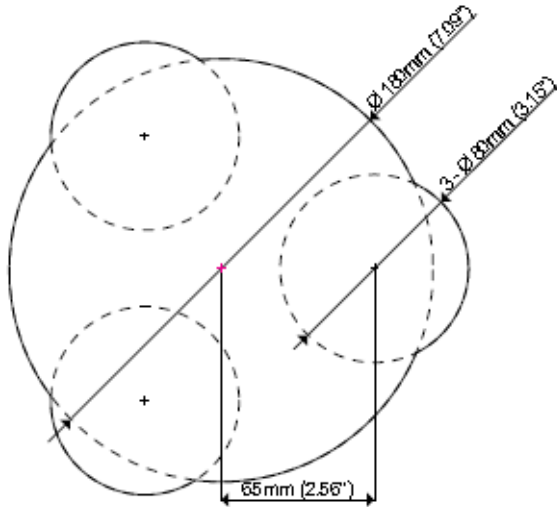

- ② Align main body bracket with flush mount bracket. Fasten with screws.

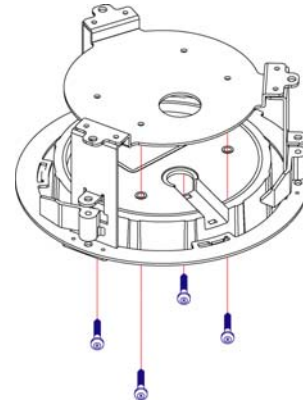

- ③ Connect fall-proof spring to main body hook. Assemble and fasten with screws.

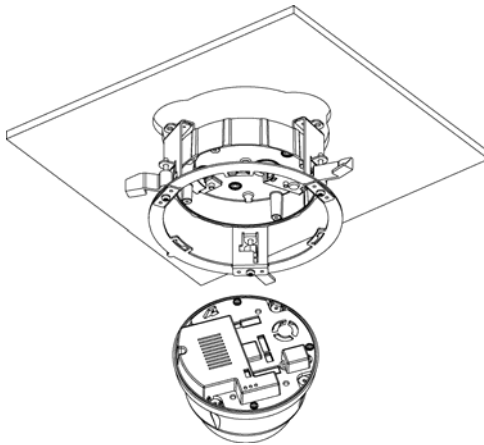

- ④ Put main body and bracket assembly into main hole.

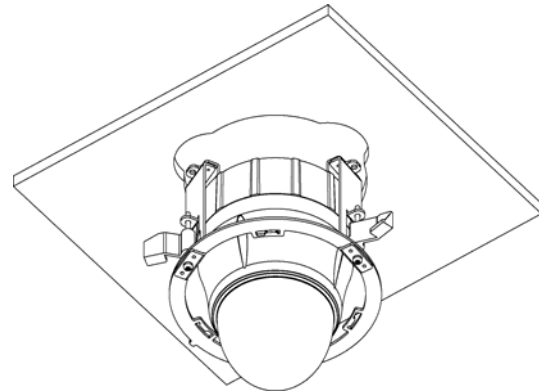

- ⑤ Secure flush mount bracket to the ceiling with screws through the 3 holes on the bracket.

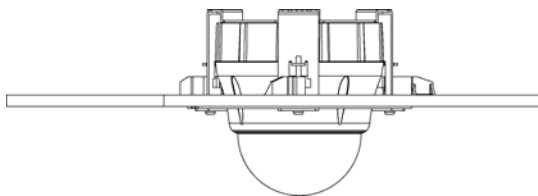

- ⑥ Cover assembly with bracket cover and turn it clockwise.

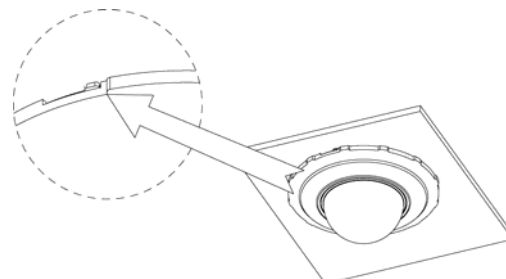

Cabling

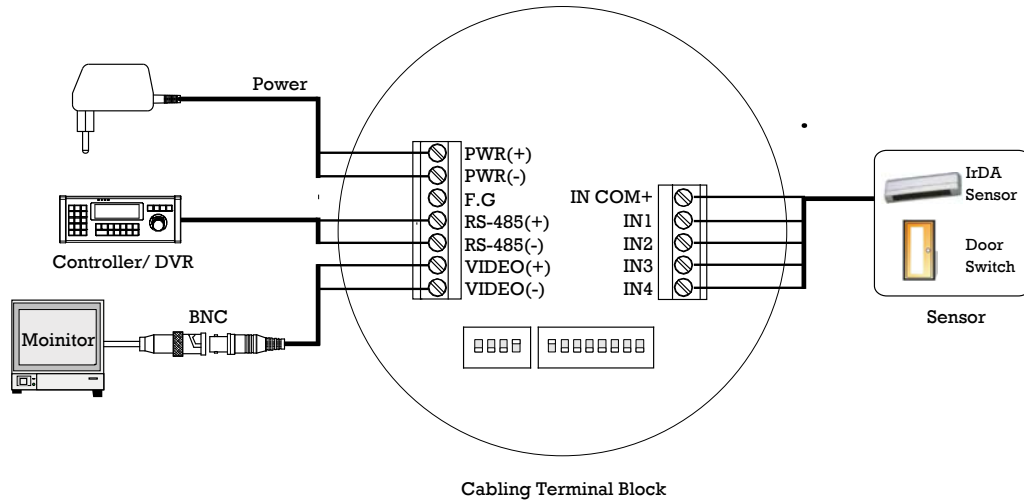

Power Connection

- Please check the voltage and current capacity of rated power carefully. Rated power is indicated on the back of main unit.

Rated Power	Input Voltage Range	Current Consumption
AC 24V (PT112N)	AC 17V ~ 29V	0.4 A
AC 24V (PT112N-XT)	AC 17V ~ 29V	1.5 A

- DC power loss increases over distance. DC power wiring to cameras should be kept as short as possible.

RS-485 Communication

- For PTZ control, connect the RS-485 line to keyboard and DVR. To control multiple cameras on the same line with simultaneous operation (see page 13 for resistor settings): the RS-485 communication lines to cameras are connected in parallel as shown below.

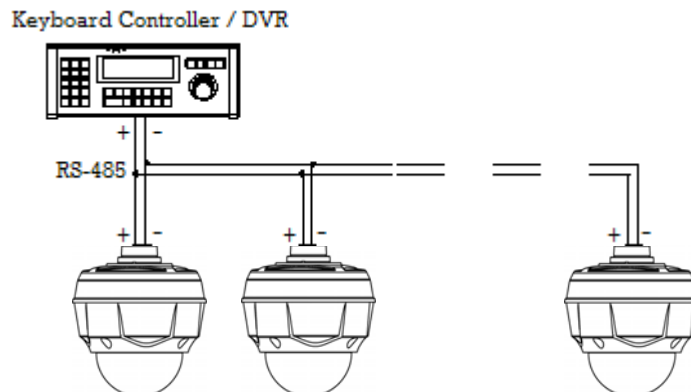

❑ Video Connection

- Connect with BNC coaxial cable.

❑ Alarm Input Connection

- Sensor Input

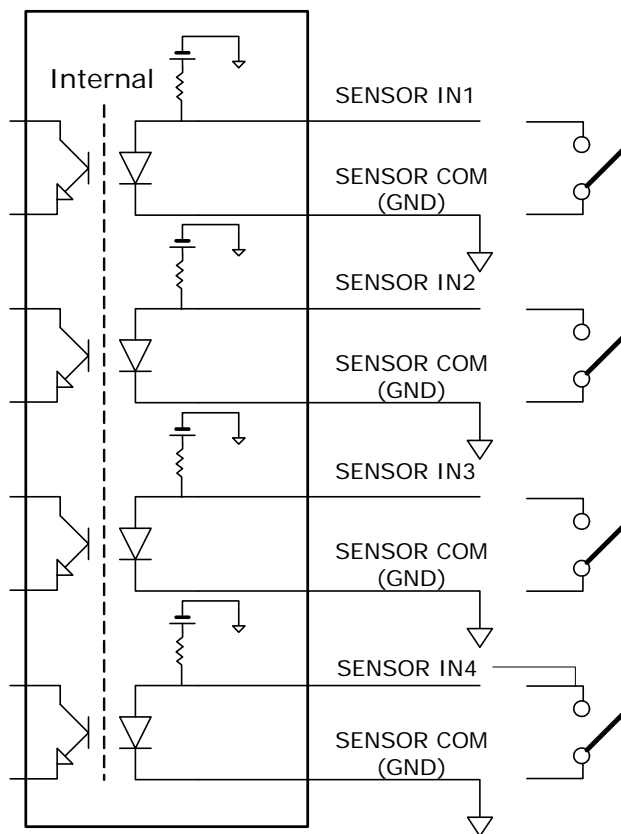

Before connecting sensors, check the sensor driver voltage and output signal type. Since sensor output signal types are divided into Open Collector and Voltage Output types in general, the cabling must be installed properly depending on the signal type.

Signal	Description
IN COM (GND)	Connect SENSOR COMs to this port(GND) as shown in the circuit above.
IN1, IN2, IN3, IN4	Connect output of sensors for each port as shown in the circuit above.



If you want to use Alarm Input, the type of sensor must be selected in OSD menu. The sensor types are Normal Open and Normal Close. If the sensor type is not selected properly, alarm activation will occur opposite of what is desired.

<input type="radio"/> Normal Open	Output Voltage is high state when sensor is activated
<input type="radio"/> Normal Close	Output Voltage is high state when sensor is not activated

Check Points before Operation

- Before power is applied, please check the cables carefully.
- The camera ID of the controller must be identical to that of the target camera. The camera ID can be checked by reading DIP switch of the camera.
- If your controller supports multi-protocols, the protocol must be changed to match to that of the camera.
- If you changed camera protocol by changing DIP switch, the change will be effective after you reboot the camera.
- Since the operation method can be different for each controller available, refer to the manual for your controller if camera can not be controlled properly. The operation of this manual is based on the standard Pelco® Controller.

Preset and Pattern Function Pre-Check

- Check controller or DVR preset and pattern functions in advance when using controller or DVR.
- Refer to the following table when using standard Pelco® protocol controller.

< Go Preset >	Input [Preset Number] and press [Preset] button.
< Set Preset >	Input [Preset Number] and press [Preset] button for more than 2 seconds.
< Run Pattern >	Input [Pattern Number] and press [Pattern] button.
< Set Pattern >	Input [Pattern Number] and press [Pattern] button for more than 2 seconds.

- If controller or DVR has no pattern button or function, use shortcut keys with preset numbers. For more information, refer to “Reserved Preset” in this manual.

Starting OSD Menu

- **Function** Using the OSD menu, Preset, Pattern, Swing, Group and Alarm Input function can be configured for each application
- **Enter Menu** <Go Preset> [95]

Reserved Preset

- **Description** Some Preset numbers are reserved to special functions.
- **Function**
 - Go Preset [95] : Enters into OSD menu
 - Go Preset [131~134] : Runs Pattern Function 1 ~ 4
 - Go Preset [141~148] : Runs Swing Function 1 ~ 8
 - Go Preset [151~158] : Runs Group Function 1 ~ 8
 - Go Preset [170] : Sets Camera BLC Mode to OFF
 - Go Preset [171] : Sets Camera BLC Mode to ON
 - Go Preset [174] : Sets Camera Focus Mode to AUTO
 - Go Preset [175] : Sets Camera Focus Mode to Manual
 - Go Preset [176] : Sets Camera Focus Mode to SEMI-AUTO
 - Go Preset [177] : Sets Day & Night Mode to AUTO
 - Go Preset [178] : Sets Day & Night Mode to NIGHT
 - Go Preset [179] : Sets Day & Night Mode to DAY
 - Go Preset [182] : Sets Camera IRIS mode to AUTO**
 - Go Preset [183] : Sets Camera IRIS mode to Manual**
 - Go Preset [190] : Sets OSD Display Mode to AUTO (Except Privacy Mask)
 - Go Preset [191] : Sets OSD Display Mode to OFF (Except Privacy Mask)
 - Go Preset [192] : Setting OSD Display Mode to ON (Except Privacy Mask)
 - Go Preset [193] : Sets all Privacy Mask Display to OFF
 - Go Preset [194] : Sets all Privacy Mask Display to ON



Preset

- **Function** Max. 127 positions can be stored as Preset position. The Preset number can be assigned from 1 to 128, but 95 is reserved for starting OSD menu.
Camera characteristics (i.e. White Balance, Auto Exposure) can be set up independently for each preset. Label should be blank and "Camera Adjust" should be set to "GLOBAL" as default. All characteristics can be set up in OSD menu.
- **Set Preset** <Set Preset> [1~128]
- **Run Preset** <Go Preset> [1~128]
- **Delete Preset** To delete Preset, use OSD menu.

Swing

- **Function** By using Swing function, the camera can move between 2 Preset positions repeatedly. When swing function runs, camera moves from the preset assigned as the 1st point to the preset assigned as the 2nd point in CW (Clockwise) direction. Then camera moves from the preset assigned as the 2nd point to the preset assigned as the 1st point in CCW (Counterclockwise) direction.

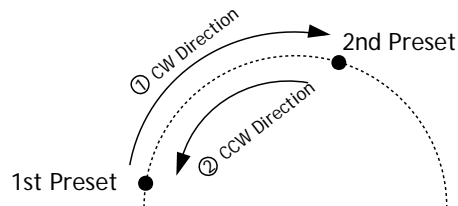

If the preset assigned as the 1st point is the same as the preset assigned as the 2nd point, the camera will turn 360° in a CW (Clockwise) direction, then 360° in a CCW (Counterclockwise) direction.

Speed can be set up from 1°/sec to 180°/sec.

- **Set Swing** To set Swing, use OSD menu.
- **Run Swing** Method 1) <Run Pattern> [Swing NO.+10] ex) Run Swing 3 : <Run Pattern> [13]
Method 2) <Go Preset> [Swing NO.+140] ex) Run Swing 3 : <Go Preset> [143]
- **Delete Swing** To delete Swing, use OSD menu.



Pattern

- **Function** Pattern Function allows the camera to memorize a path (often a curved path) created by controller joystick for an assigned time. The camera will then retrace the path exactly as memorized.

4 Patterns are available and Maximum 1200 communication commands can be stored in a pattern.

- **Set Pattern** Patterns can be created by one of following two methods.

Method 1) <Set Pattern> [Pattern NO.]

- Pattern editing screen is displayed as bellow.

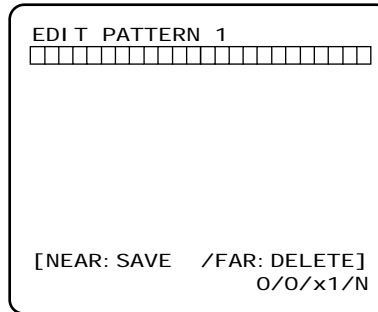

- Movement by Joystick and preset movement can be memorized in a pattern.
- The remaining memory size is displayed in progress bar.
- To save the recording, press **NEAR** key and to cancel, press **FAR** key.

Method 2) OSD Using OSD Menu: See the section "How to use OSD Menu".

- **Run Pattern** Method 1) <Run Pattern> [Pattern NO.] ex) Run Pattern 2 : <Run Pattern> [2]

Method 2) <Go Preset> [Pattern NO.+130] ex) Run Pattern 2: <Go Preset> [132]

- **Delete Pattern** Use OSD menu to delete a Pattern.

Group

- **Function** The group function allows a running sequence of Presets, Pattern and/or Swings. Max 8 groups can be stored. Each group can have max 20 action entities which can be preset, pattern or swing. Preset speed can be set up and the repeat number of Pattern & Swing can be set up in Group setup. Dwell time between actions can also be set up.

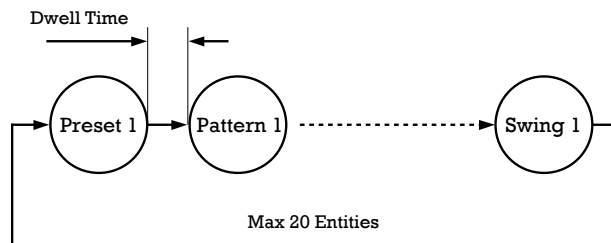

- **Set Group** Use OSD Menu to create a Group.
- **Run Group**
Method 1) <Run Pattern> [Group NO.+20] ex) Run Group 7 : <Run Pattern> [27]
Method 2) <Go Preset> [Group NO.++150] ex) Run Group 7 : <Go Preset> [157]
- **Delete Group** Use OSD Menu to delete.



Other Functions

- **Power Up Action** This function enables the camera to resume the last action executed before power down. Most actions such as Preset, Pattern, Swing and Group are available for this function, but Jog actions cannot be resumed.
- **Auto Flip** If the tilt angle arrives at the top of tilt orbit (90°), zoom module camera will keep moving in the opposite tilt direction (180°) to keep tracing targets. As soon as the camera (lens) passes through the top of tilt direction (90°), images will be reversed automatically and the  symbol appears on screen. If this function is set to OFF, tilt movement range is 0 ~ 95°.
- **Parking Action** This function sets the camera to a specific position automatically if operator doesn't operate the controller for a while. The Park Time can be defined as an interval from 1 minute to 4 hours.
- **Alarm Input** 4 Alarm Inputs are used. If an external sensor is activated, camera can be set to move to corresponding preset position. Note: the latest alarm input is in effect if multiple sensors are activated.
- **Privacy Zone Mask** To protect privacy, MAX. 8 Privacy Masks can be created in arbitrary locations to hide objects such as windows, shops or private houses. With the Spherical Coordinates system, a powerful Privacy Zone Mask function is available.
- **GLOBAL/LOCAL Image Setup** WB (White Balance) and AE (Auto Exposure) can be set up independently for each preset. There are 2 modes, "Global" mode & "Local" mode. The Global mode means that WB or AE can be set up simultaneously for all presets in the "ZOOM CAMERA SETUP" menu. The Local mode means that WB or AE can be set up independently or separately for each preset in each preset setup menu. Each Local WB/AE value will activate correspondingly as the camera arrives at each preset location.

During jog operation, Global WB/AE values should be applied. All Local WB/AE values will not change although Global WB/AE value changes.
- **Semi-Auto Focus** Automatically selects focus mode from Manual Focus or Auto Focus depending on type of operation. Manual Focus mode activates in preset operation and Auto Focus mode activates during jog operation. In Manual mode, Focus data for each preset is memorized in advance, and the camera calls focus data for corresponding presets as soon as it arrives at a preset. This method shortens focus times.

Focus mode changes to Auto Focus mode automatically when jog operation starts.

OSD Display of Main Screen

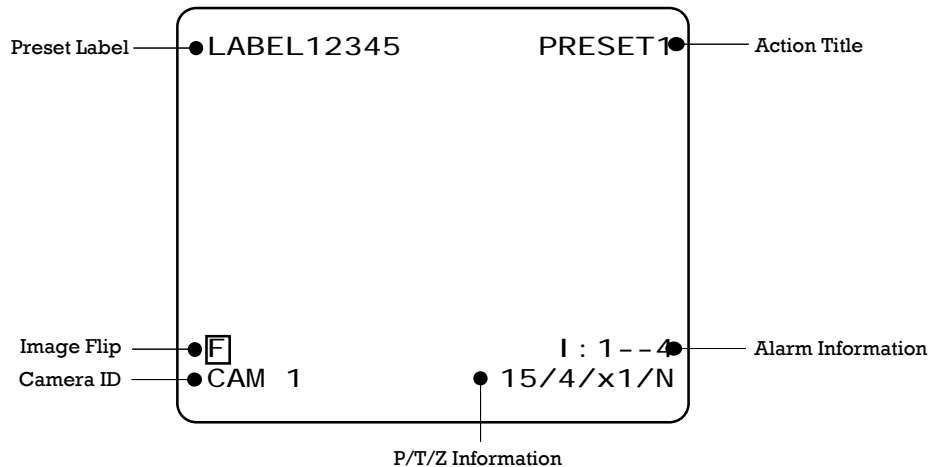

- P/T/Z Information Current Pan/Tilt angle in degree, zoom magnification and a compass direction.
- Camera ID Current Camera ID (Address).
- Action Title Followings are possible Action Titles and their meaning.

"SET PRESET xxx"	When Preset xxx is stored
"PRESET xxx"	When camera reach to Preset xxx
"PATTERN x"	When Pattern x is in action
"SWGx/PRESET xxx"	When Swing x is in action
"UNDEFINED"	When undefined function is called to run
- Preset Label The Label stored for specific Preset.
- Alarm Input This information shows current state of Alarm Input. If an Input point is **ON** it will show a number corresponding to each point. If an Input point is **OFF**, '-' will be displayed.
Example - if points 2 & 3 of inputs are **ON**, the OSD will show as below:

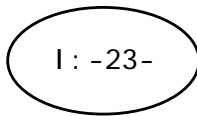

- Image Flip Indicates that images are currently reversed by Auto Flip Function.

General Rules of Key Operation for Menu

- The menu items surrounded with () always have a sub menu.
- At all menu levels, to go into sub menu, press **NEAR** key.
- To go to up one menu level, press **FAR** key.
- To move from items to item in the menu, use joystick in the **Up/Down** or **Left/Right**.
- To change a value of an item, use **Up/Down** of the joystick in the controller.
- Press **NEAR** key to save values and Press **FAR** key to cancel values.

Main Menu

```
SPEED DOME CAMERA
-----
-><SYSTEM INFORMATION>
<DI SPLAY SETUP>
<DOME CAMERA SETUP>
<SYSTEM I N I T I A L I Z E>

EXI T
```

- **System Information** Displays system information and configuration.
- **Display Setup** Enable/Disable of OSD display on Main Screen.
- **Dome Camera Setup** Configure various functions of this camera.
- **System Initialize** Initializes system configuration and sets all data to factory default configuration.

Display Setup

```

DISPLAY SETUP
-----
->CAMERA ID          ON
PTZ INFORMATION     AUTO
ACTION TITLE        AUTO
PRESET LABEL         AUTO
ALARM INPUT          AUTO
<SET NORTH DIRECTION>
<PRIVACY ZONE>

BACK
EXIT
    
```

This menu defines Enable/Disable of OSD display on Main Screen. If an item is set to be AUTO, the item is displayed only when the value of it is changed.

- Camera ID [ON/OFF]
- PTZ Information [ON/OFF/AUTO]
- Action Title [ON/OFF/AUTO]
- Preset Label [ON/OFF/AUTO]
- Alarm Input [ON/OFF/AUTO]

Compass Direction Setup

```

SET NORTH DIRECTION
-----

MOVE TO TARGET POSITION
[NEAR: SAVE /FAR: CANCEL
    
```

Set North to assign compass direction as criteria. Move camera and press **NEAR** button to save.

Privacy Zone Mask Setup

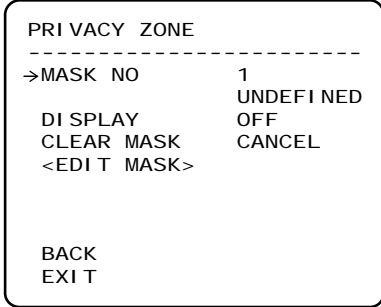

Select area in image to mask.

- Mask No [1~8]
Select Mask number. If the selected mask has already data, camera moves as it was set. Otherwise, "UNDEFINED" will be displayed under "Mask NO".
- Display [ON/OFF]
Sets if camera makes mask shows or not on images.
- Clear Mask [CANCEL/OK]
Deletes data in the selected mask NO.

Privacy Zone Area Setup

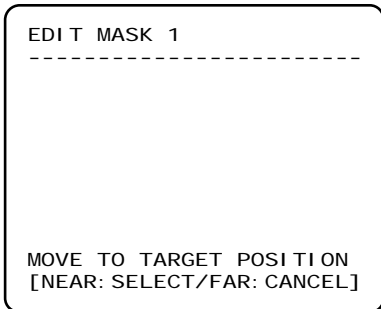

Move camera to area to mask. Then the menu to adjust mask size will be displayed.

Privacy Zone Size Adjustment

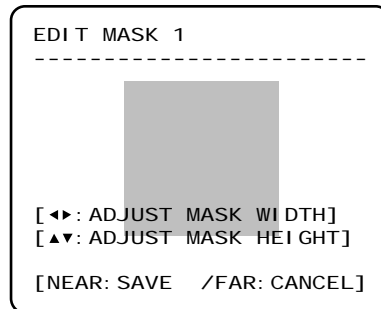

Adjust mask size. Use joystick or arrow buttons to adjust mask size.

- ◀ ▶ (Left/Right)
- ▲ ▼ (Up/Down)



Camera Setup

```

ZOOM CAMERA SETUP
-----
-> FOCUS MODE      SEMI AUTO
   DIGITAL ZOOM   ON
   IMAGE FLIP     OFF
   SHARPNESS      2
   STABILIZATION  OFF
   <WHITE BALANCE SETUP>
   <AUTO EXPOSURE SETUP>

BACK
EXIT

```

Setup the general functions of zoom camera module.

- **Focus Mode** [AUTO/MANUAL/SEMI-AUTO]

Sets camera focus mode.

○ SEMI-AUTO Mode

Automatically selects focus mode from Manual Focus or Auto Focus depending on type of operation. Manual Focus mode activates in preset operation and Auto Focus mode activates during jog operation. In Manual mode, Focus data for each preset is memorized in advance, and the camera calls focus data for corresponding presets as soon as it arrives at a preset.

- **Digital Zoom** [ON/OFF]

Sets digital zoom function to ON/OFF. When set to OFF, optical zoom function runs but zoom function stops at the end of optical zoom magnification.

- **Image Flip** [ON/OFF]

Turn watching direction to the other side of moving when camera gets vertical sight.

- **Sharpness** [0~3]

Sets image sharpness to enhance pictures.

- **Stabilization** [ON/OFF]

Compensates image vibrations by wind or others. The images with vibrations are compensated by Digital Zoom function and the image resolution with this function should be lower than normal image when this function is turned off.

☐ White Balance set up

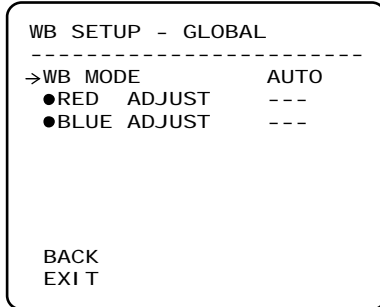

- WB Mode [AUTO/MANUAL]
In Manual mode, Red and Blue level can be set up manually
- Red Adjust [0~255]
- Blue Adjust [0~255]

☐ Auto Exposure Setup

```

AE SETUP - GLOBAL
-----
->BACKLI GHT      OFF
DAY/NI GHT       AUTO
BRI GHTNESS      32
I R I S           AUTO
SHUTTER          ---
AGC              ---
SSNR             MI DDLE
SENS-UP          <AUTO>
BACK
EXI T
    
```

- Backlight [ON/OFF]
Sets Backlight Compensation
- Day/Night [AUTO/DAY/NIGHT]
Sets up Day&Night mode
- Brightness [0~64]
Adjusts brightness of images. Iris, Shutter Speed and Gain are adjusted automatically in correspondence with this value.
- IRIS [AUTO/MANUAL(0~64)]
If Iris is set to Auto, Iris should have highest priority in adjusting AE and Shutter Speed should be fixed.
If Iris is set to Manual, Iris should be fixed and Iris has lower priority in adjusting AE, in comparison with others.
- Shutter Speed [A.Flicker/Manual(1/60(50)~1/10000 sec)]
If Iris is set to Manual and Shutter Speed is set to ESC, Shutter Speed should have highest priority. If Shutter Speed is set to A.Flicker, to remove Flicker, Shutter Speed should be set to 1/100 sec. for NTSC and 1/120 for PAL.
- AGC [OFF/LOW/MIDDLE/HIGH/MANUAL(0~15)]
Enhances image brightness automatically in case that luminance level of image signal is too low.
- SSNR [OFF/LOW/MIDDLE/HIGH]
Enhances images by filtering noise when gain level of images is too high.
- SENS-UP [AUTO(2~256)/OFF]
Activates Slow Shutter function when luminance of image (signal) is too dark.
It is possible to set up the maximum number of frames stacked on one another by Slow Shutter function.

Motion Setup

```

MOTION SETUP
-----
->MOTION LOCK      OFF
PWR UP ACTION     ON
AUTO FLIP         ON
JOG MAX SPEED     120/SEC
JOG DIRECTION     INVERSE
FRZ IN PRESET     OFF
<PARKING ACTION SETUP>
<ALARM INPUT SETUP>
BACK
EXIT
    
```

Setup the general functions of Pan/Tilt motions.

- **Motion Lock** [ON/OFF]

If Motion Lock is set to ON, it is impossible to set up and delete Preset, Swing, Pattern and Group. It is only possible to run these functions. To set up and delete these functions, enter into OSD menu.
- **Power Up Action** [ON/OFF]

Refer to "Other Functions" section.
- **Auto Flip** [ON/OFF]

Refer to "Other Functions" section.
- **Jog Max Speed** [1°/sec ~360°/sec]

Sets maximum jog speed. Jog speed is inversely proportional to zoom magnification. As zoom magnification goes up, pan/tilt speed goes down.
- **Jog Direction** [INVERSE/NORMAL]

If you set this to 'Inverse', the view on the screen will move in the same direction as jog tilt. If 'Normal' is selected, the view on the screen will move in the opposite direction.
- **Freeze in Preset** [ON/OFF]

At start point of preset movement, camera will freeze the image of start point. Camera keeps displaying the image of start point during preset movement and does not display the images received during preset movement. As soon as camera stops at preset end point, camera will display live images received at the preset end point.

Availability of this function will vary by model.



❑ Parking Action Setup

```

PARKING ACTION SETUP
-----
->PARK ENABLE    OFF
   WAIT TIME     00: 10: 00
   PARK ACTION    HOME

BACK
EXIT
  
```

If Park Enable is set to ON, camera runs assigned function automatically if there is no PTZ command during assigned "Wait Time".

- Park Enable [ON/OFF]
- Wait Time [1~59 sec/1~180 minute]
The time is displayed with "hh:mm:ss" format and can be changed in 1 min units.
- Park Action [HOME/PRESET/PATTERN/SWING/GROUP]
○ HOME
Camera moves to home position if there is no PTZ command during assigned "Wait Time".

❑ Alarm Input Setup

```

ALARM INPUT SETUP
-----
->ALARM NO.      1

TYPE            N. OPEN
ACTION          NOT USED
HOLD TIME       ENDLESS
POST ACTION     HOME

BACK
EXIT
  
```

Matches the Alarm sensor input to one of Preset positions. If an external sensor is activated, camera will move to corresponding preset position when this item is predefined.

- Alarm × Type [Normal OPEN/Normal CLOSE]
Sets sensor input type.
- Alarm × Action [NOT USED/PRESET/PATTERN,SWING/GROUP]
Assign counteraction Preset position to each Alarm input.
- Hold Time [ENDLESS/1~59 sec/1~180 minute]
Sets the time period for the action which is run by external sensor activation. After the time period passes, the action pre-defined in "Post Action" runs sequentially in succession to the action by external sensor activation. If this option is set to "ENDLESS", "Post Action" does not activate.
- Post Action [HOME/PRESET/PATTERN/SWING/GROUP/PREV ACTION]



Preset Setup

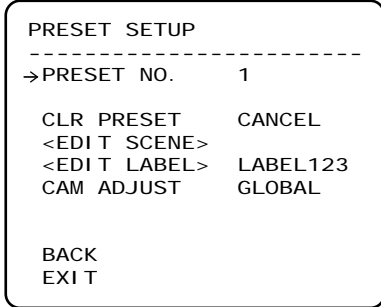

- **Preset Number** [1~128]
If a selected preset is already defined, camera moves to pre-defined position and preset characteristics such as Label and Relay Outputs show on monitor. If a selected preset is not defined, "UNDEFINED" shows on monitor.
- **Clear Preset** [CANCEL/OK]
Delete current Preset data
- **Edit Preset Scene** Redefine current Preset scene position (i.e. PTZ).

❑ Edit Preset Scene

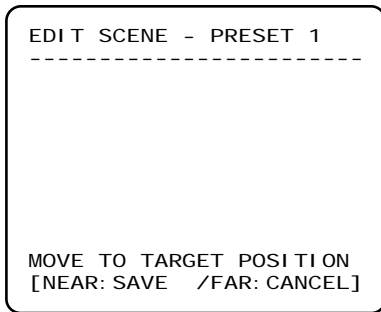

- ① Using Joystick, move camera to desired position.
- ② By pressing **NEAR** key, save current PTZ data.
- ③ Press **FAR** key to cancel.

Swing Setup

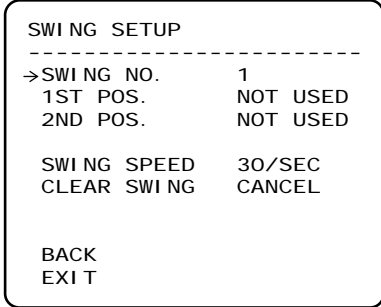

- **Swing Number** [1~8]
Select Swing number to edit. If a selected Swing is not defined, "NOT USED" is displayed in 1st Position and 2nd Position

- **1st Position** [PRESET 1~128]
2nd Position Set up the 2 position for Swing function. If a selected preset is not defined, "UNDEFINED" will be displayed as shown below.

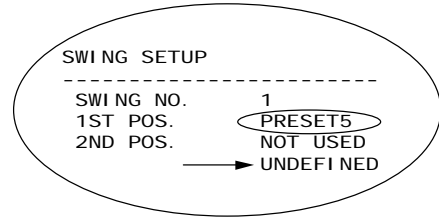

When swing function runs, the camera will move from the preset assigned as the 1st point to the preset assigned as the 2nd point in a CW (Clockwise) direction. Then the camera will move from the preset assigned as the 2nd point to the preset assigned as the 1st point in a CCW (Counterclockwise) direction. If the preset assigned as the 1st point is same as the preset assigned as the 2nd point, the camera will turn 360° in CW direction and then turn 360° in CCW direction.

- **Swing Speed** [1°/sec ~180°/sec]
Sets Swing speed from 1°/sec to 180°/sec.

- **Clear Swing** [CANCEL/OK]
Deletes current Swing data.



Pattern Setup

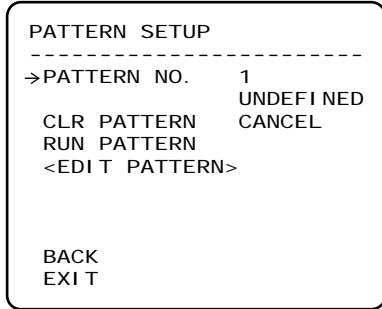

- **Pattern Number** [1~4]
Selects Pattern number to edit.
If a selected pattern number is not defined, "UNDEFINED" will be displayed under selected pattern number.
- **Clear Pattern** [CANCEL/OK]
Deletes data in current pattern
- **Run Pattern** Runs Pattern for the test purposes to check if it works properly.
- **Edit Pattern** Starts editing pattern.

□ Edit Pattern

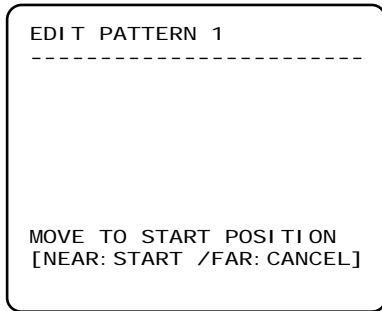

① Using Joystick, move to start position with appropriate zoom. To start pattern recording, press **NEAR** key. To exit this menu, press **FAR** key.

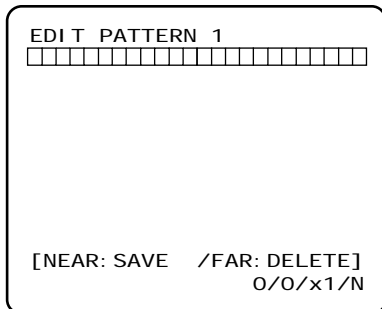

② Move camera with controller joystick or run preset function to memorize a path (often a curved path) in a selected pattern. The total memory size and remaining memory size are displayed in the form of a bar. Maximum 1200 communication commands can be stored in a pattern.

③ To save data and exit, press **NEAR** key. To cancel recording and delete record data, press **FAR** key.

Group Setup

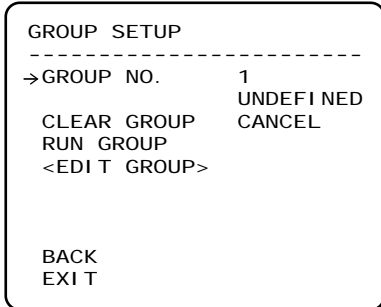

Edit Group

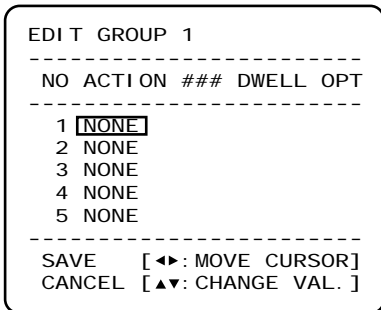
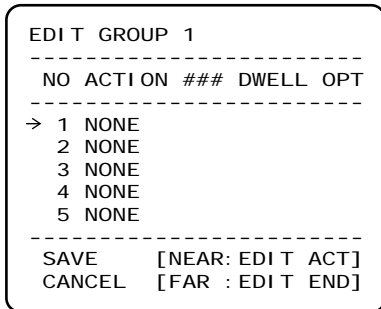
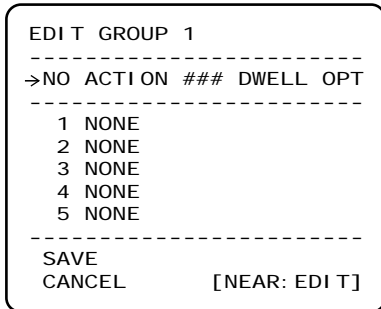

- **Group Number** [1~8]
Selects Group number to edit.
If a selected Group number is not defined, "UNDEFINED" will be displayed under selected Group number.

- **Clear Group** [CANCEL/OK]
Deletes data in current Group

- **Run Group** Runs Group for the test purposes.

① "Press **Near** key in "NO" list to start Group setup.

② Note that MAX. 20 Functions are allowed in a Group. Move cursor up/down and press **Near** key to set up.

③ Set up Action, Dwell time and Option. Note that selected item is displayed in reverse. Move cursor **Left/Right** to select items and move cursor **Up/Down** to change each value.

- **Action ###** [NONE/PRESET/SWING/PATTERN]

- **DWELL** [0 second ~ 4 minutes]
Sets Dwell Time between functions

- **OPT** Option. Displays the preset speed when preset is set in Action. Displays the number of repeats when Pattern or Swing is selected in Action

```

EDIT GROUP 1
-----
NO ACTION ### DWELL OPT
-----
 1 PRESET  1 00: 03 360
 2 NONE
 3 NONE
 4 NONE
 5 NONE
-----
SAVE  [◀▶: MOVE CURSOR]
CANCEL [▲▼: CHANGE VAL. ]
    
```

- ④ Set up items such as Action, ###, Dwell and OPT.

```

EDIT GROUP 1
-----
NO ACTION ### DWELL OPT
-----
-> 1 PRESET  1 00: 03 360
 2 NONE
 3 NONE
 4 NONE
 5 NONE
-----
SAVE  [NEAR: EDIT ACT]
CANCEL [FAR : EDIT END]
    
```

- ⑤ After finishing setup of an Action, press **Near** key to one-upper-level menu (Step ②). Move cursor **Up/Down** to select Action number and repeat Step ② ~ Step ④ to edit selected Group.

```

EDIT GROUP 1
-----
NO ACTION ### DWELL OPT
-----
 1 PRESET  1 00: 03 360
 2 NONE
 3 NONE
 4 NONE
 5 NONE
-----
->SAVE
CANCEL
    
```

- ⑥ After finishing setup of all Actions, press **FAR** key to exit. Then cursor should be moved to "SAVE". Press **Near** key to save data.

System Initialize

SYSTEM INITIALIZE	

→CLEAR ALL DATA	NO
●CLR DISPLAY SET	NO
●CLR CAMERA SET	NO
●CLR MOTION SET	NO
●CLR EDIT DATA	NO
REBOOT CAMERA	NO
REBOOT SYSTEM	NO
BACK	
EXIT	

- **Clear All Data** Deletes all configuration data, such as display, camera, and motion setup.
- **Clear Display Set** Initializes Display Configuration
- **Clear Camera Set** Initializes Camera Configuration
- **Clear Motion Set** Initializes Motion Configuration
- **Clear Edit Data** Deletes Preset Data, Swing Data, Pattern Data and Group Data
- **Reboot Camera** Reboots Zoom Camera module
- **Reboot System** Reboots Speed Dome Camera

Initial Configuration Table

● Display Configuration		● Camera Configuration	
Camera ID	ON	Focus Mode	SemiAuto
PTZ Information	AUTO	Digital Zoom	ON
Action Title	AUTO	Image Flip	OFF
Preset Label	AUTO	Sharpness	2
Alarm Input	AUTO	Stabilization	OFF
North Direction	Pan 0°	White Balance	AUTO
Privacy Zone	Undefined	Backlight	OFF
● Motion Configuration		Day&Night	AUTO
Motion Lock	OFF	Brightness	32
Power Up Action	ON	Iris	AUTO
Auto Flip	ON	Shutter	---
Jog Max Speed	120°/sec	AGC	---
Jog Direction	INVERSE	SSNR	MIDDLE
Freeze In Preset	OFF	SENS-UP	AUTO
Park Action	OFF	● User Edit Data	
Alarm Action	OFF	Preset 1~128	Undefined
		Swing 1~8	Undefined
		Pattern 1~4	Undefined
		Group 1~8	Undefined



Specifications

Model		PT112N / PT112N-XT ×12		
Video Signal System		NTSC	PAL	
Camera	CCD	1/4" Super-HAD CCD		
	Max. Pixels	811(H)×508(V) 410K	795(H)×596(V) 470K	
	Effective Pixels	768(H)×494(V) 380K	752(H)×582(V) 440K	
	Horizontal Res.	560 TVL (Color), 600 TVL (B/W)		
	S/N Ratio	52 dB (AGC Off)		
	Zoom	×12 Optical Zoom, ×12 Digital Zoom		
	Focal length	F1.6, f=3.6~44.3mm		
	Min. illumination	2.0 Lux (Color) / 0.0008 Lux (B/W), 50 IRE		
	Day & Night	Auto / Day / Night(ICR)		
	Focus	Auto / Manual / SemiAuto		
	Iris	Auto / Manual		
	Shutter Speed	1/60(50) ~ 1/10000 sec		
	AGC	Auto / Manual		
	White Balance	Auto / Manual(Red, Blue Gain Adjustable)		
	BLC	On / Off		
	Flickerless	Selectable		
SSNR	Low / Middle / High / Off			
Pan/Tilt	Range	Pan : 360°(Endless) Tilt : 180° (Auto-Flip), 95° (Normal)		
	Pan/Tilt Speed	Preset :	360°/sec	
		Manual :	0.05 ~ 360°/sec (proportional to zoom)	
		Swing :	1~ 180°/sec	
	Preset	127 Preset (Label, Camera Image Setting)		
	Pattern	4 Pattern, 880 commands(about 5 minute)/Pattern		
	Swing	8 Swing		
	Group	8 Group (20 action entities per Group)		
Other Functions	Auto Flip, Auto Parking, Power Up Action etc.			
General	Communication	RS-485		
	Protocol	Pelco-D, Pelco-P selectable		
	Privacy Zone	8 Zone		
	Alarm Input	4 Input		
	OSD	Menu / PTZ information etc		
	Rated Power**	DC Type :	DC 12V / 0.8A , *DC 12V / 2.5A	
		AC Type :	AC 24V / 0.4A , *AC 24V / 1.5A	
	Dimension	Dome :	∅115	
		Ceiling	∅178× 233(H) mm	
		Housing	∅154.5 × 158.5(H) mm , *∅178 × 244(H)×289(H) mm	
Weight	Main Unit	Approx. about 1.3 Kg, *1.9 Kg		
	Ceiling	Approx. *2.2Kg		
	Wall	Approx. *2.5Kg		
Operating Temp.	0°C ~ 40°C , (*-30 ~ 50°C / -22~ 122°F)			
IEC-529 Standard	*IP66			

* PT112N-XT Model Only

** Check the voltage and current capacity of rated power carefully.

*** Specifications of this product are subject to change without notice.

■ Appearance*

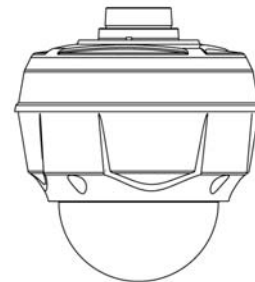

Main Unit

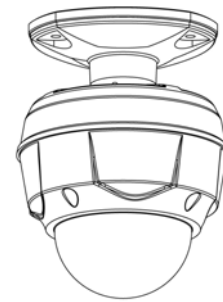

Ceiling

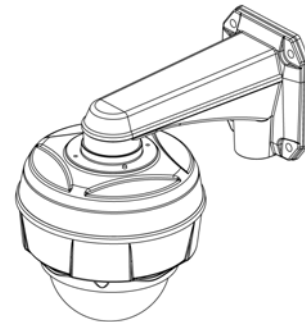

Wall

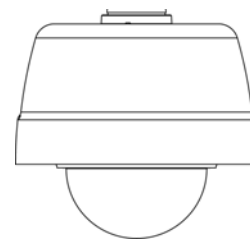

Sun shield

Note: PT112N-XT. PT112N appearance will vary, see

page 38 for PT112N appearance specifications.



Dimensions-PT112N Indoor Model

● Main Unit & Surface Mount Bracket

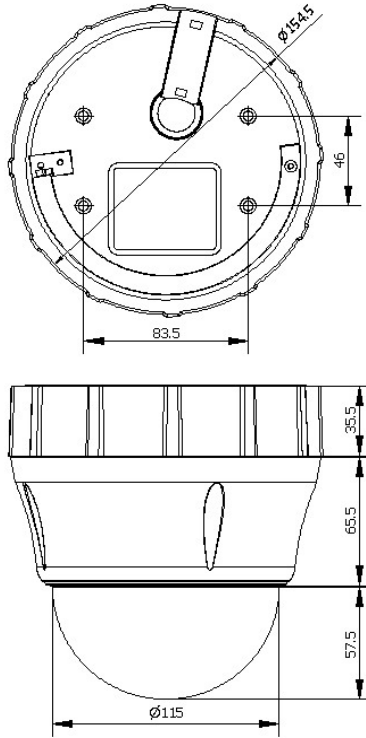

● Ceiling Mount Bracket

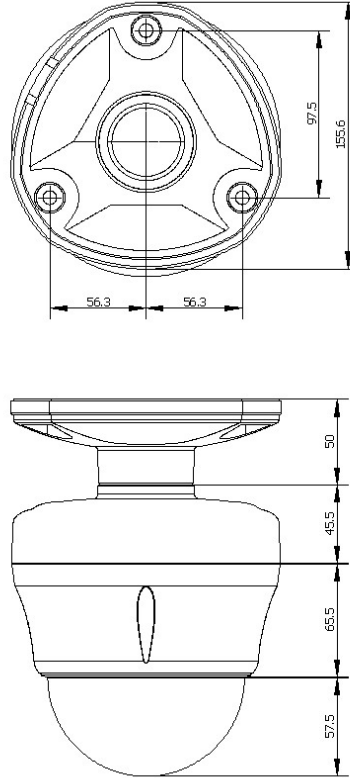

● Wall Mount Bracket

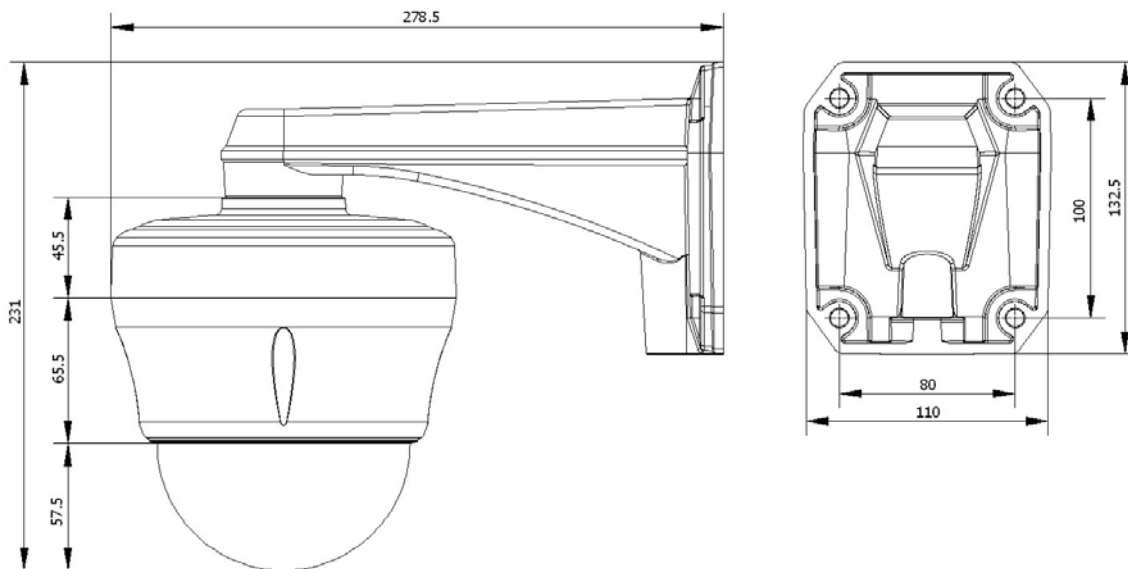

Unit: mm



Dimensions-PT112N-XT Outdoor Model

● Ceiling Mount Bracket

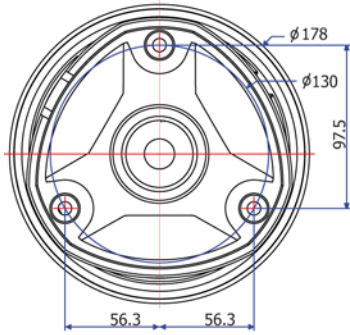

● Sun shield

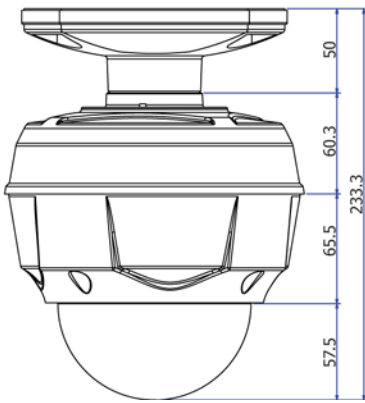
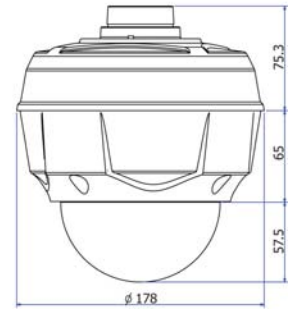
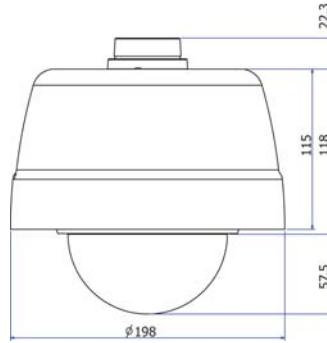

● Wall Mount Bracket

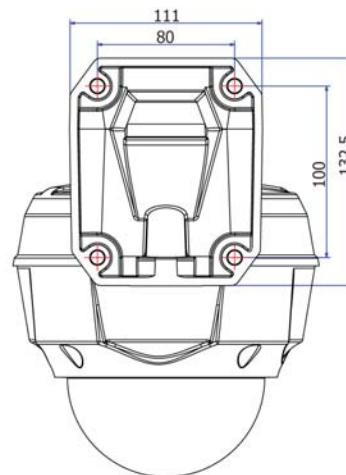
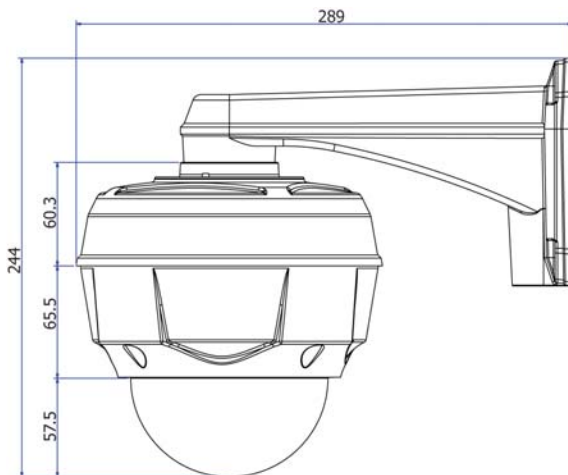

Unit: mm



NOTES: