

## ALSO/KEVIS CCTV CAMERA HOUSING SERIES

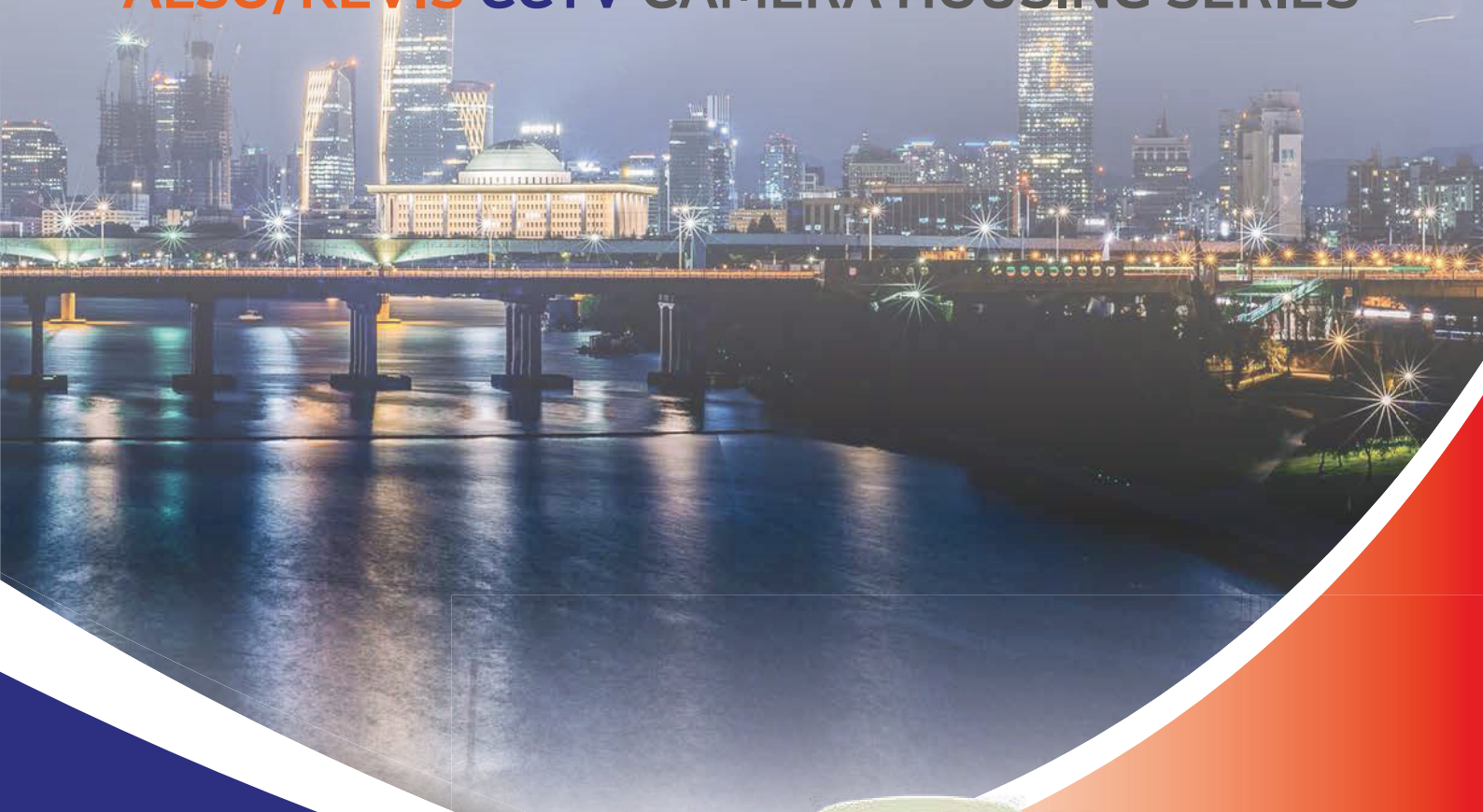

OPTION : KBR-080CC BRACKET

# PH-5120 SHB

Indoor / Outdoor Plastic Housing

### PH Seires

- Indoor / Outdoor Plastic Housing
- IP66 Rated, Side Open Design
- Smart Heater/Fan (Option)
- Optional PoE Module for IP Camera
- Options : Sun shield (S), Heater (H), Blower (B)

POSITIONING / PAN-TILT / IR PTZ / **HOUSING** / BRACKET / RACK / OTHERS

# KEVIS



#### Specifications

Usage & Open Type	Indoor / Outdoor & Side Hinge Type
Options	Sunshield (S), Heater (H), Blower (B), PoE(P), Gore Valve(G), IR LED Lamp(IR)
Body & Color	ABS Plastic UV protected & Cool Gray 1C
Power	AC 24V(20W) / AC115V(25W) / AC 230V(25W)
Typical Airflow	450MI/MIN (Gore Valve)
Temperature of Use	DH-5100S : 4°C~+50°C DH-5100SHBD : -20°C~+50°C (Heater, Blower)
Safety Certification	CE
IP Rating	IP66
Accessories	Spring Washa M6, Flat Washer M6, Screw 1/4"-20X3/8" 2 ea

※ Designs and Specifications may differ from the latest products, please contact our sales for the update.  
· IP66 (Ingress Protection, International Dustproof / Waterproof) is applied when installed and assembled correctly.

#### Features

- Indoor / Outdoor Plastic Housing
- IP66 Rated, Side Open Design
- Smart Heater/Fan (Option)
- Optional PoE Module for IP Camera
- Options : Sun shield (S), Heater (H), Blower (B)

#### Model Options

1. PH-5120S (Sun Shield)
2. PH-5120SH (Sun Shield, Heater)
3. PH-5120SHB (Sun Shield, Heater, Blower)

#### Product Inside



#### Dimensions

Model & Weight	Outside (mm)	Inside (mm)
PH-5120 (0.95kg)	150.8(W) x 136.7(H) x 385(D)	78.9(W) x 67.1(H) x 273(D)
PH-5120H (1.5kg)	150.8(W) x 136.7(H) x 385(D)	78.9(W) x 67.1(H) x 273(D)
PH-5120HB (1.8kg)	150.8(W) x 136.7(H) x 385(D)	78.9(W) x 67.1(H) x 273(D)

#### Drawings

UNIT(mm)

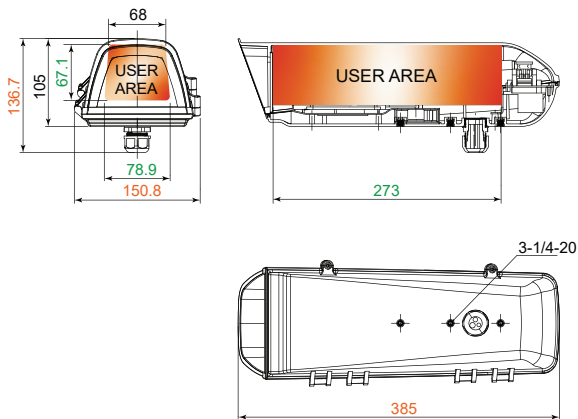

#### Accessories

UNIT(mm)

| KBR-080CC | Wall Mount

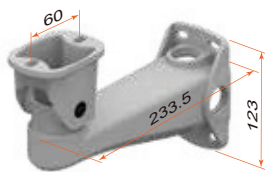

#### Specifications

Material	Aluminum
Weight	1.2kg
Max. Loading	15kg
Color	Cool Gray 2C
Pan/Tilt	360° / 90°
Dimensions	73 x 172 x 252

| KBR-1000 | Wall Mount

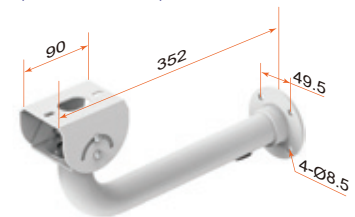

#### Specifications

Material	Aluminum
Weight	1kg
Max. Loading	15kg
Color	Cool Gray 2C
Pan/Tilt	360° / 90°
Dimensions	352 x 184.5 x 89