



- Provides standard XLR and RCA connectors for Lectrosonics automatic mixers
- 8 balanced XLR inputs
- Alternate RCA jacks on 2 inputs
- Balanced XLR output
- Dual mono RCA outputs
- Switchable -10dB output attenuator on RCA jacks
- Depluggable connectors on rear

The XLR8 adapter panel converts the audio connectors on the AM8 automatic mixer to standard XLR and RCA types for use in rental, staging or mobile applications where audio cables are connected and disconnected frequently. The panel is often mounted on either the front or rear of an ATA style case or other rack mount.

Lectrosonics 3-pin depluggable connectors (P/N 21531) are used to interconnect the XLR8 panel with the mixer.

Inputs 7 and 8 offer RCA jacks as an alternative to the XLR connectors for use with tape decks or other audio equipment. Slide switches located on the rear of the panel select either the RCA or XLR jack as the active input.

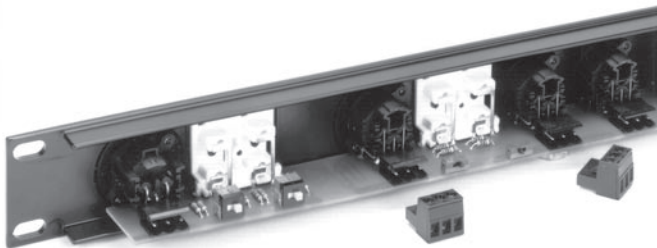

All output connectors are active simultaneously to feed several different types of equipment at the same time, such as a PA mixer, VCR and audio tape recorder. Each pair of RCA outputs provides a switch selectable 10dB attenuator to properly match the levels needed for a variety of professional and consumer audio equipment.

Depluggable connectors on the rear of the XLR8 provide a wide variety of wiring arrangements in balanced or unbalanced configurations. If a device is connected to the RCA type inputs 7 or 8, the rear panel switch should be in the UNBAL position. XLR jacks are selected with the BAL position of these switches.

The XLR and RCA output jacks are electrically in parallel. The XLR output jacks are balanced while the RCA output jacks are unbalanced. The left and right pairs of RCA jacks also provide switchable 0dB and -10dB attenuation.

If output attenuation other than -10dB is desired, refer to the diagram below for values and placement of resistors.

The input and output XLR jacks are connected in a fully balanced form as follows:

- Pin 1 - Ground
- Pin 2 - Signal Hi
- Pin 3 - Signal Lo

The input and output RCA jacks are connected in an unbalanced form as follows:

- Center pin - Signal Hi
- Outside ring - Ground

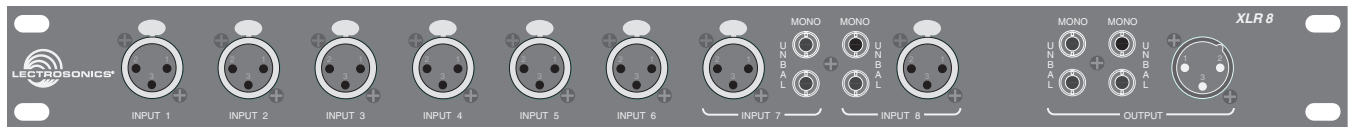
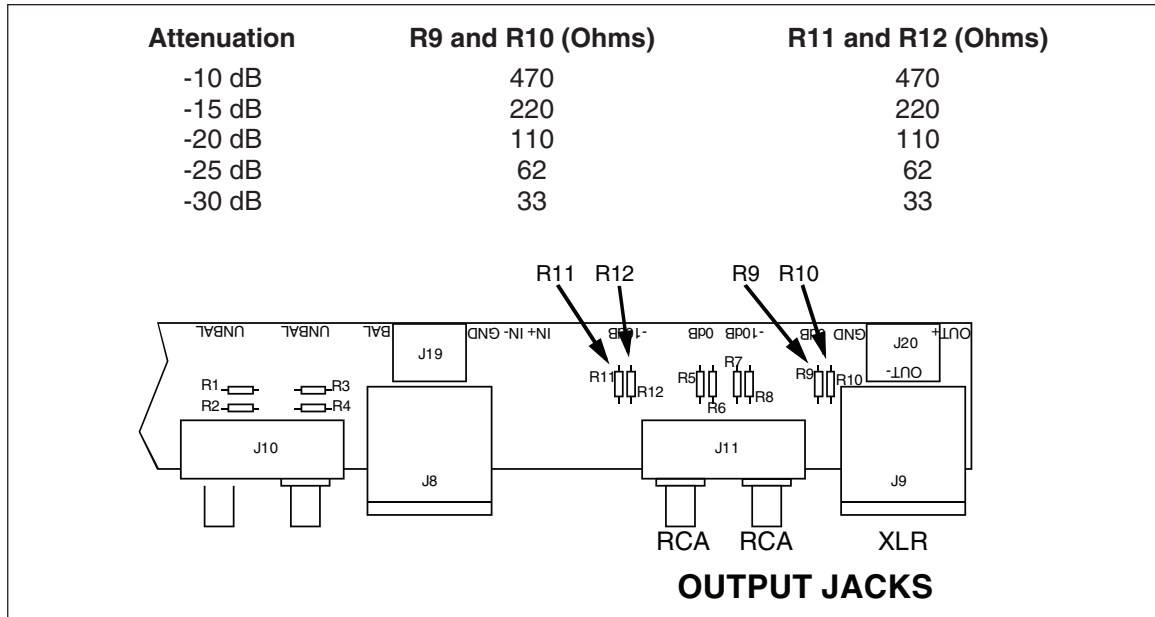

- Connectors:**
 Input: 8 - XLR; 2 - RCA pairs (Inputs 7 and 8 switchable between XLR and RCA type)
 Output: 1 - XLR; 2 - RCA pairs with internal 1KOhm buildout resistance
- Weight:** 0.5 lbs.
- Dimensions:** 19.00" wide, 1.75" high, 1.80" deep

