

REV	CHANGE RECORD AND DATE	CH
-----	------------------------	----

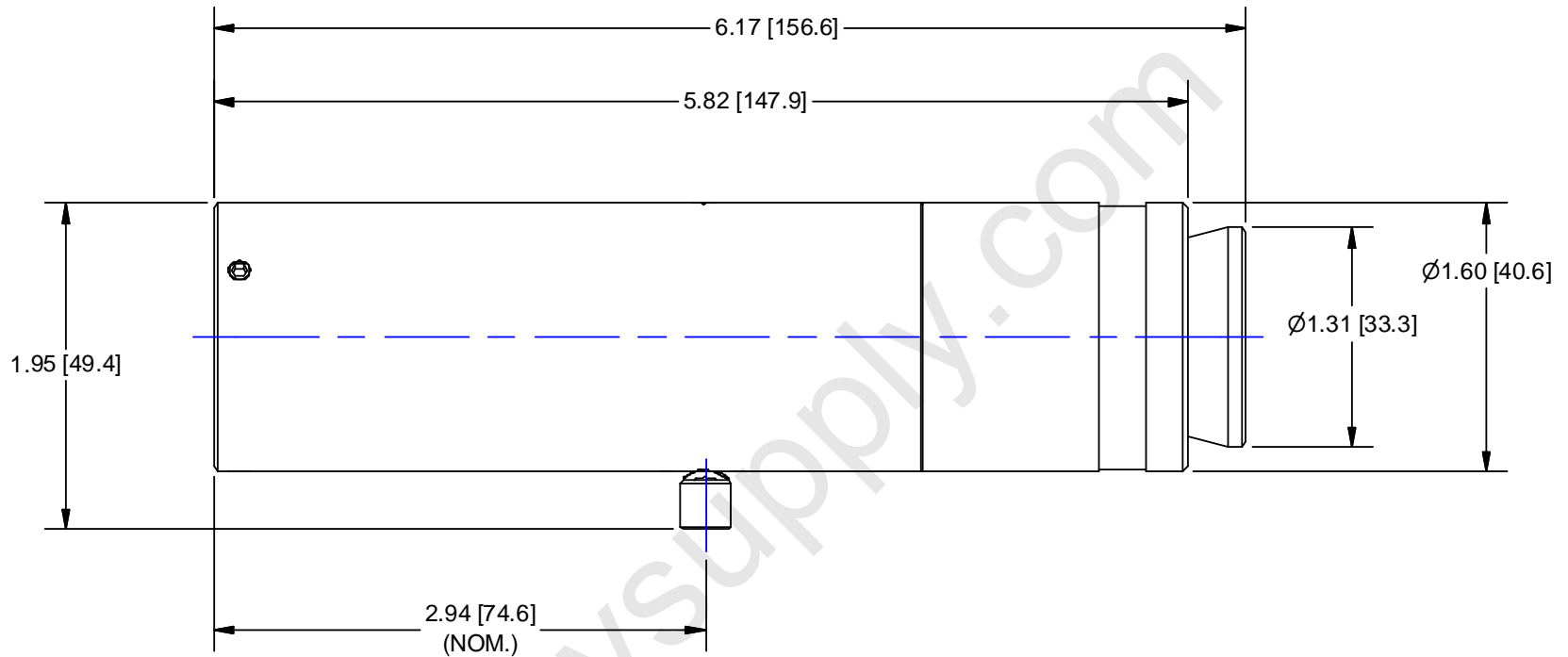

OUTLINE

USED ON:

MATERIAL:

UNLESS OTHERWISE SPECIFIED DIMENSIONS ARE IN INCHES AND INCLUDE CHEMICALLY APPLIED OR PLATED FINISHES

TOLERANCES AS FOLLOWS

DEC. .XXX ± .005
 DEC. .XX ± .010
 FRACT. ± 1/64
 ANGLES ± 30'
 CONCENTRICITY .003 TIR

BREAK ALL SHARP EDGES
 .005 MIN. .010 MAX.

MAX. SURF. ROUGHNESS: 32

P/N SUFFIX DEFINITION

- 1 CONVERSION COATING
- 2 PAINTING
- 3 MARKING
- R REWORK

SCALE: 1:1

DR: R. PODLENA

CH:

APP:

DATE DR: 6/16/2003

DO NOT SCALE DRAWING

THE CONTENTS OF THIS DOCUMENT ARE PROPRIETARY TO NAVITAR, ITS USE IS AUTHORIZED ONLY FOR RESPONDING TO REQUEST FOR QUOTATION OR PERFORMANCE OF WORK FOR NAVITAR

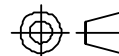
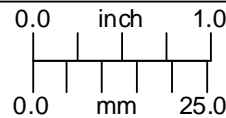

ROCHESTER, NEW YORK

5X ADAPTER (RIGHT ANGLE)

SIZE

1-6187 01

REV

A

SH

CHAMFER ALL THREADS 30° TO ROOT DIAMETER

For design help, accessories or pricing, please contact:
 sales@avsupply or call: 1-858-565-1101

AUDIOVIDEO SUPPLY
 1-800-284-2288 sales@avsupply.com
 www.avsupply.com