

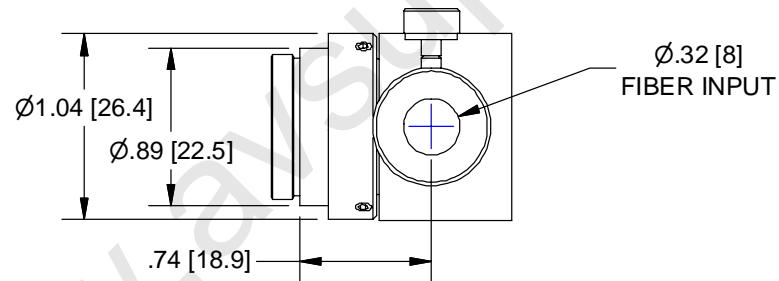



SCALE 1 : 1

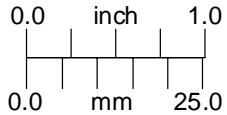
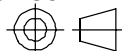

OUTLINE

UNLESS OTHERWISE SPECIFIED DIMENSIONS ARE IN INCHES AND INCLUDE CHEMICALLY APPLIED OR PLATED FINISHES		THE CONTENTS OF THIS DOCUMENT ARE PROPRIETARY TO NAVITAR, ITS USE IS AUTHORIZED ONLY FOR RESPONDING TO REQUEST FOR QUOTATION OR PERFORMANCE OF WORK FOR NAVITAR				
SCALE:	2:1					12X 8mm PARALLEL COAX ASS'Y
WEIGHT:	0.1LBM			DO NOT SCALE DRAWING		
DR:	R. PODLENA			A	SHE	
CH:						
PROJECT #:						
DATE DR:	11/12/2003					1-800-284-2288 sales@avsupply.com www.avsupply.com

For design help, accessories or pricing, please contact:
 sales@avsupply or call: 1-858-565-1101