

MTVF3.3X0313IR-BCDN

Type	AI VARI		Mount	ø14 Straight Mount		
Focal Length	3.0~10.0mm		Back Focus	5.4~12.3mm		
Fno.	F1.3		Flange Back	13.8mm		
Designed Image Format	1/3"(4.8x3.6mm)		Exit Pupil	-87.6 ~ -21.1mm		
Operation Range	Iris	F1.3-F360	Filter Size	-		
	Focus	0.5m~ ∞	Aperture	Front ø 15.9mm		
	Zoom	3.0~10.0mm		Rear ø 6.5mm		
Control	Iris	DC Galvanometer	Dimension	ø29 x 37.9mm		
	Focus	Manual			Weight	31g
	Zoom	Manual				
Object Size at MOD	Wide	697.7x1123.9mm				
	Tele	194.2x261.5mm				
Field of View	D	1/3" $\frac{127.2^{\circ} \sim 36.0^{\circ}}$	1/4" $\frac{88.2^{\circ} \sim 27.0^{\circ}}$			
	H	$\frac{95.6^{\circ} \sim 28.8^{\circ}}$	$\frac{68.8^{\circ} \sim 21.6^{\circ}}$			
	V	$\frac{68.8^{\circ} \sim 21.6^{\circ}}$	$\frac{50.6^{\circ} \sim 16.2^{\circ}}$			
Control	Iris		Focus	Zoom		
Driving Coil/Supply Volt.	190Ω		-	-		
Damping Coil/Current	855Ω		-	-		
IR Cut Filter	3V ~ 5V		-	-		
Response Time	-		-	-		
Potentiometer	-		-	-		
Light Measuring Method	-		-	-		
Input Signal	-		-	-		
Iris Accuracy	-		-	-		
Sensitivity Adjustment	-		-	-		
Operating Temperature	-20 ~ +50 degree C		-	-		

1/3"

FM

BCDN

DIMENSIONS

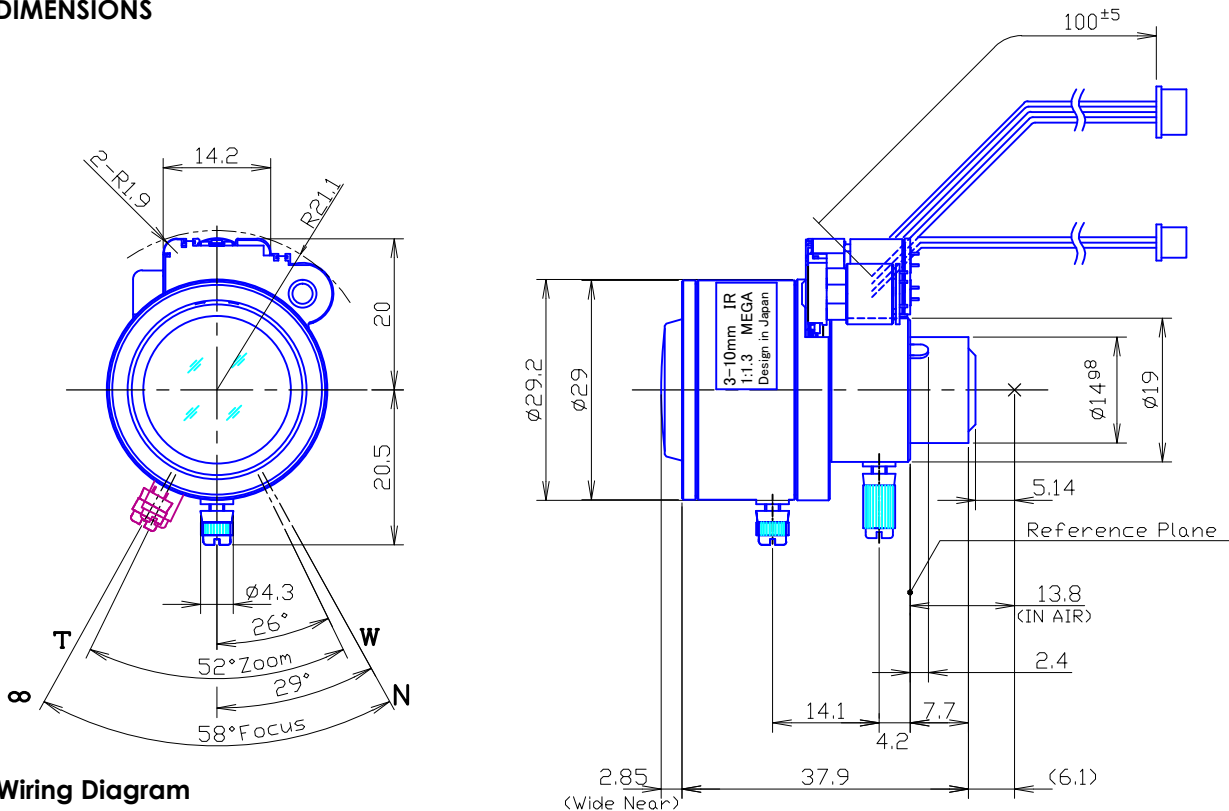

Wiring Diagram

1) 4-pin Connector for Auto Iris
(Molex : 51021-0400 Single Socket)

Pin No.1	Yellow	Damping(+)	▶
2	Orange	Damping(-)	
3	Brown	Driving (+)	
4	Red	Driving (-)	

2) 2-pin Connector for IR Cut Filter
(Molex : 51021-0200 Single Socket)

Pin No.1	Red	IR IN/OUT(+)	▶
2	Black	IR GND	