

SENTECH

STC-CL/CLC152A Specification Manual

**Small Cubic Type - SXGA CCD
Color / Monochrome Camera Link Camera**

For design help, accessories or pricing, please contact:
sales@avsupply or call: 1-858-565-1101

AUDIOVIDEO SUPPLY
1-800-284-2288 sales@avsupply.com
www.avsupply.com

Distributed By: Audio Video Supply -- Tel: 1-800-284-2288 -- www.avsupply.com

Safety Precautions

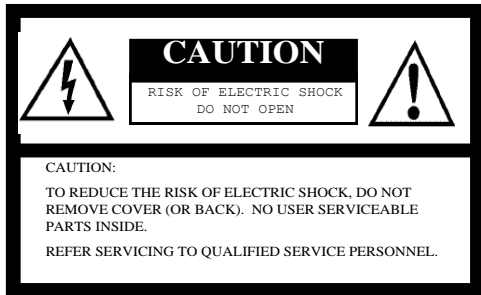

For U.S.A.

Warning:

This equipment generates and uses radio frequency energy and if not installed and used properly, i.e., in strict accordance with the instruction manual, may cause harmful interference to radio communications. It has been tested and found to comply with the limits for a Class A computing device pursuant to Subpart J of Part 15 of FCC Rules, which are designed to provide reasonable protection against such interference when operated in a commercial environment.

For Canada

Warning:

This digital apparatus does not exceed the Class A limits for radio noise emissions from digital apparatus set out in the Radio Interference Regulations of the Canadian Department of Communications.



The lightning flash with arrowhead symbol, within an equilateral triangle, is intended to alert the user to the presence of uninsulated "dangerous voltage" within the product's enclosure that may be of sufficient magnitude to constitute a risk of electric shock to persons.



The exclamation point within an equilateral triangle is intended to alert the user to the presence of important operating and maintenance (servicing) instructions in the literature accompanying the appliance.

WARNING:

TO PREVENT FIRE OR SHOCK HAZARD, DO NOT EXPOSE THIS APPLIANCE TO RAIN OR MOISTURE.

Product Precautions

- Handle the camera with care. Do not abuse the camera. Avoid striking or shaking it. Improper handling or storage could damage the camera.
- Do not pull or damage the camera cable.
- During camera use, do not wrap the unit in any material. This will cause the internal temperature of the unit to increase.
- Do not expose the camera to moisture, or do not try to operate it in wet areas.
- Do not operate the camera beyond its temperature, humidity and power source ratings.
- While the camera is not being used, keep the lens or lens cap on the camera to prevent dust or contamination from getting in the CCD or filter area and scratching or damaging this area.
- Do not keep the camera under the following conditions:
 - In wet, moist, and high humidity areas
 - Under hot direct sunlight
 - In high temperature areas
 - Near an object that releases a strong magnetic or electric field
 - Areas with strong vibrations
- Use a soft cloth to clean the camera. Use pressured air spray to clean the surface of the glass. DO not scratch the surface of the glass.

Copyright & Disclaimer

Sensor Technologies America, Inc. (DBA Sentech America) believes the contents and specifications of its website, catalog, documentation and ads are correct; however, Sentech America provides no representation or warranty regarding such information or product(s) contained therein. It is requested that Sentech America be given appropriate acknowledgement in any subsequent use of such work by a third party.

While every effort has been made to ensure that the details contained in Sentech America's website and all documentation are correct and up-to-date, Sentech America assumes no liability, legal or otherwise for any errors in listings, specifications, part numbers, process, software or model applications. Sentech America reserves the right to change specifications, product descriptions, product quality, pricing and application at any time without prior written or oral notice. Any party using such information assumes all risk for any and all damaged caused to themselves, a third party and/or property by virtue of incorrect information and/or failure of these products. By installing and/or using a Sentech America software development kit or other similar product and/or information obtained from Sentech America's website, catalog, documentation or ads, you hereby accept and understand these stated terms and conditions.

www.avsupply.com

Distributed By: Audio Video Supply -- Tel: 1-800-284-2288 -- www.avsupply.com

Contents

I. Specifications	5-7
A. Electronic Specifications / Mechanical Specifications / Environmental Specifications.....	5-6
B. Connector Specifications	7
II. Dimensions	8-10
A. Camera Dimensions	8
B. Tripod Dimensions	9
C. Camera Dimensions with Tripod.....	10

Distributed By: Audio Video Supply -- Tel: 1-800-284-2288 -- www.avsupply.com

I. Specifications

A. Electronic Specifications / Mechanical Specifications / Environmental Specifications

Product		STC-CLC152A	STC-CL152A	
Electronic Specifications	Imager	1/2" interline SXGA color progressive CCD: ICX205AK	1/2" interline SXGA monochrome progressive CCD: ICX205AL	
	Total Picture Elements	1434 (H) x 1050 (V)		
	Active Picture Elements	SXGA: 1360 (H) x 1040 (V)		
	Chip Size	7.6 (H) x 6.2 (V) mm		
	Cell Size	4.65 (H) x 4.65 (V) μm		
	Scanning System	Progressive		
	Scanning Method	Full scanning, Partial full scanning, ½ partial scanning, ¼ partial scanning, Variable partial scanning	Full scanning, Partial full scanning, ½ partial scanning, ¼ partial scanning, Variable partial scanning, Binning, Binning partial scanning, Binning ½ partial scanning, Binning ¼ partial scanning, Binning variable partial scanning	
	Vertical Frequency (Frame Rate)	15.28 (15fps) / 19.3 (19fps) Hz		
	Horizontal Frequency	15.998 (15fps) / 20.57 (19fps) kHz		
	Pixel Frequency	28.6363 (15fps) / 36.8181 (19fps) MHz		
	S/N Ratio (Standard Deviation)	@ 8bit output	≤ 3 Digit (Gain 0 dB)	
		@ 10bit output	≤ 10 Digit (Gain 0 dB)	
	Minimum Scene Illumination	0.13 Lux at F1.2	0.12 Lux at F1.2	
	Sync. System	Internal / External		
	Video Output	Digital 8 or 10 bit Camera Link (Base configuration)		
	Tap	1 Tap		
	Shutter Speed	OFF, 1/3 to 1/93,000 seconds (Variable at every H and clock)(15fps) OFF, 1/5 to 1/120,000 seconds (Variable at every H and clock)(19fps)		
	Gain	0 to 27 dB		
	Gamma	1.0		
	Power Supply	Input Voltage	12Vdc ± 10%	
Consumption		Less than 2.5 W		
Trigger Mode	Edge preset trigger (V-reset, Non-reset), Pulse width trigger (V-reset, Non-reset)			
Communication	RS232 via Camera Link connector			
Mechanical Specifications	Dimensions	28(W) x 28(H) x 29.5(D) mm (Not including lens mount and the connector) (28(W) x 28(H) x 40(D) mm (Not including the connector)		
	Optical Filter	No IR cut filter		
	Optical Center Accuracy	Positional accuracy in H and V directions: +/- 0.31 mm Rotational accuracy of Hand V: +/- 2.1 deg.		
	Material	Case	Front, base, and rear: Aluminum die cast (ADC12) Cover: Steel sheet covered with zinc	
		Tripod	Polycarbonate ABS	
	Lens Mount	C mount		
	Interface Connector	HR10A-7R-6PB (Hirose) or equivalent		
	Tripod	Tripod can be attached to 4 plates (4screws on the bottom plate, 3 screws on the other 3 plates)		
	Weight	Approximately 52g (Camera: 43g, tripod: 9g)		
Environmental Specifications	Temperature and Humidity	Operational	Temperature: -5 to 45°C; Relative Humidity: 0 to 85% (No condensation)	
		Storage	Temperature: -30 to 65°C; Relative Humidity: 0 to 90% (No condensation)	
	Vibration	20 Hz to 200Hz to 20Hz (5min./cycle), acceleration 10G, 3 directions 30 min. each		
	Shock	Acceleration 70G, half amplitude 6ms, 3 directions 3 times each		
	Standard Compliancy	EMS: EN61000-6-2, EMI: EN55011 (Class B)		
	RoHS	RoHS compliant		

Spectral Sensitivity Characteristics

STC-CL152A

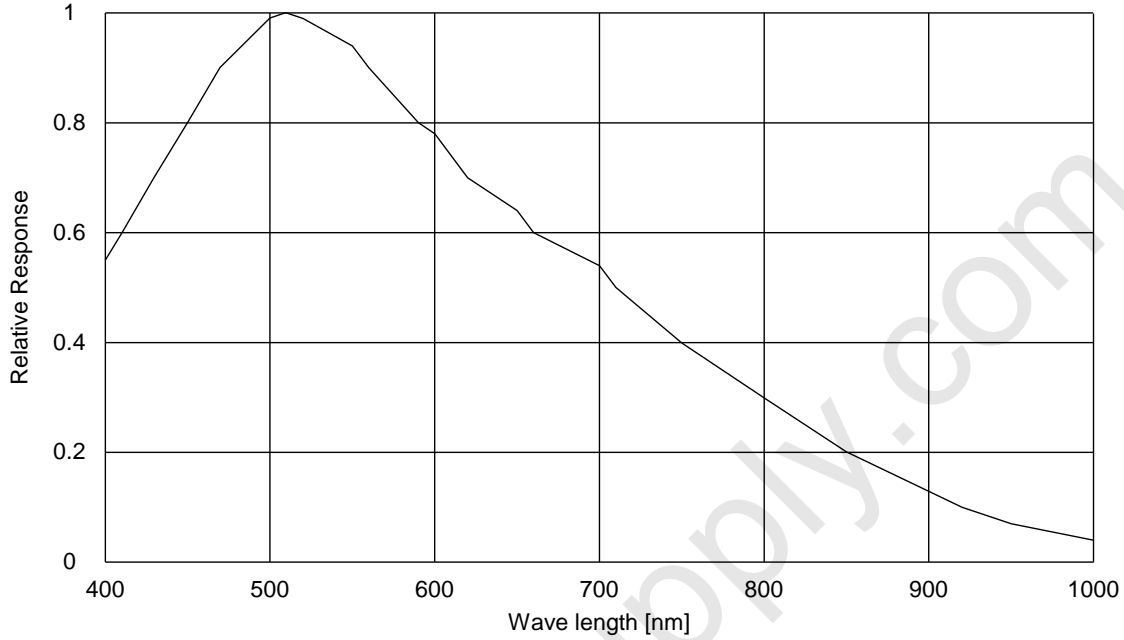

STC-CLC152A

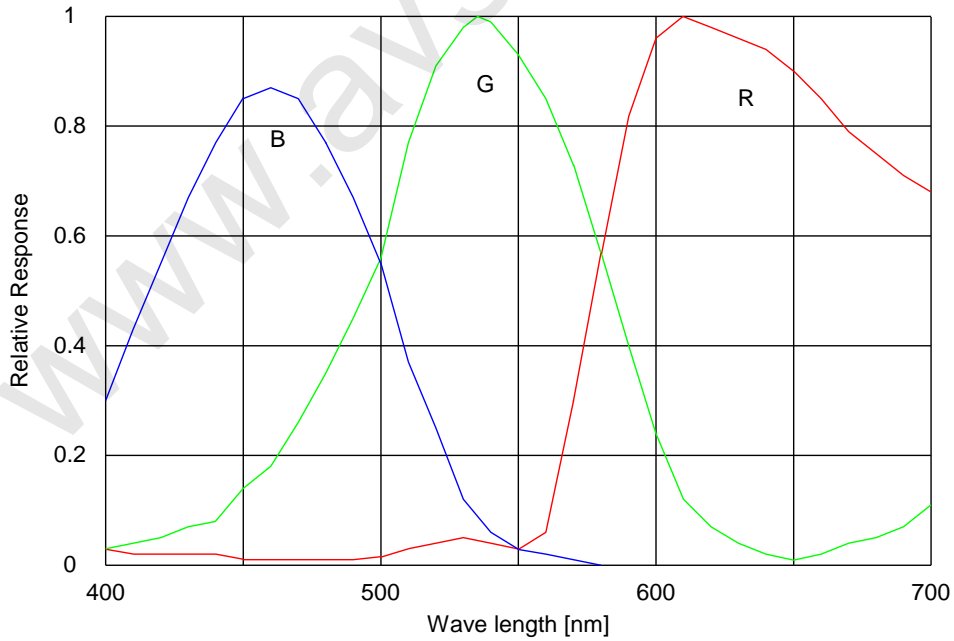

Distributed By: Audio Video Supply -- Tel: 1-800-284-2288 -- www.avsupply.com

B. Connector Specifications

1. Camera Link Connector: SDR (3M) or equivalent

Caution: This product is not PoCL type. Only apply 12V power through the interface connector.

2. Power/IO Connector: HR10A-7R-6PB (Hirose) or equivalent
This connector is for a 12av DC power input and the other input and output signals.
Trigger input and sync input/output signals can be assigned through the camera setting communication.

3. Pin Assignment:

2) Camera Link Connector

Pin No.	Signal name	Pin No.	Signal name
1	GND	14	GND
2	X0-	15	X0+
3	X1-	16	X1+
4	X2-	17	X2+
5	Xclk-	18	Xclk+
6	X3-	19	X3+
7	SerTC+	20	SerTC-
8	SerTFG-	21	SerTFG+
9	CC1- (TRG)	22	CC1+ (TRG)
10	CC2+	23	CC2-
11	CC3-	24	CC3+
12	CC4+	25	CC4-
13	GND	26	GND

B. Interface Connector

Pin No.	Signal name	IN/OUT	Voltage		
			Low voltage	High voltage	
1	GND	IN	0V		
2	I/O-1	IN/OUT	IN	0 to +0.5V	+2.5 to +5.0V
			OUT	0V	+3.3V
3	I/O-2	IN/OUT	IN	0 to +0.5V	+2.5 to +5.0V
			OUT	0V	+3.3V
4	I/O-3	IN/OUT	IN	0 to +0.5V	+2.5 to +5.0V
			OUT	0V	+3.3V
5	TRG OUT	OUT	OUT	0V	+3.3V
6	+12V	IN	+12V		

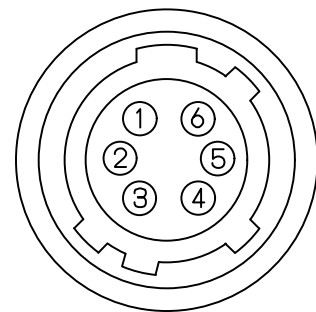

Notes: Trigger input signal can be assigned either on Camera Link connector (CC1) or on the No. 2 pin of the Power/IO connector through the camera setting communication.

The external sync signals (HD and VD) can be assigned on the following connectors through the camera setting communication:

- Camera Link connector (CC2: HD signal input, CC3: VD signal input) **or**
Power/IO connector (No.4: HD signal input / output, No3: VD signal input / output)

II. Dimensions

2) Dimensions

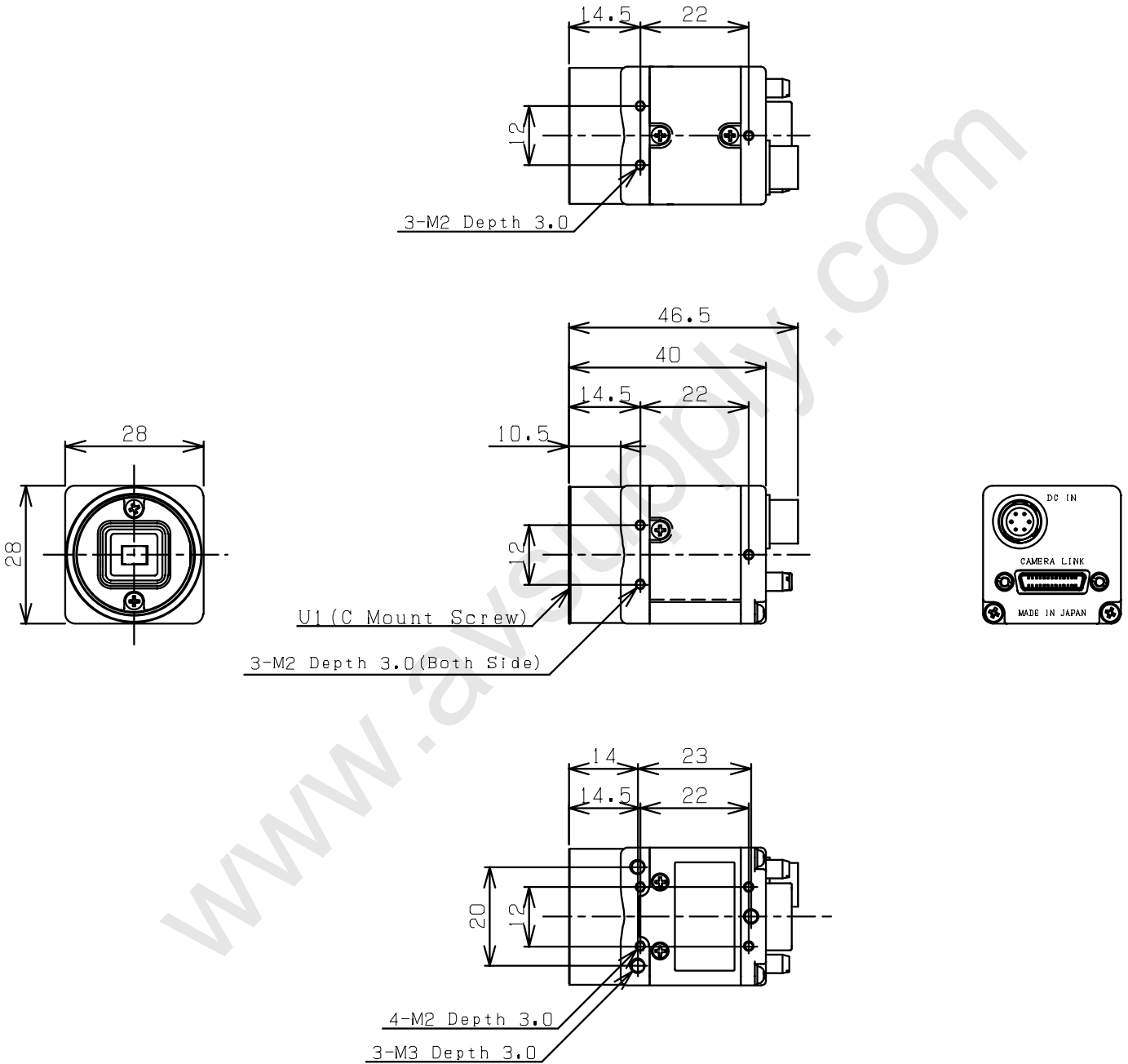

Unit: mm

B. Tripod Dimensions

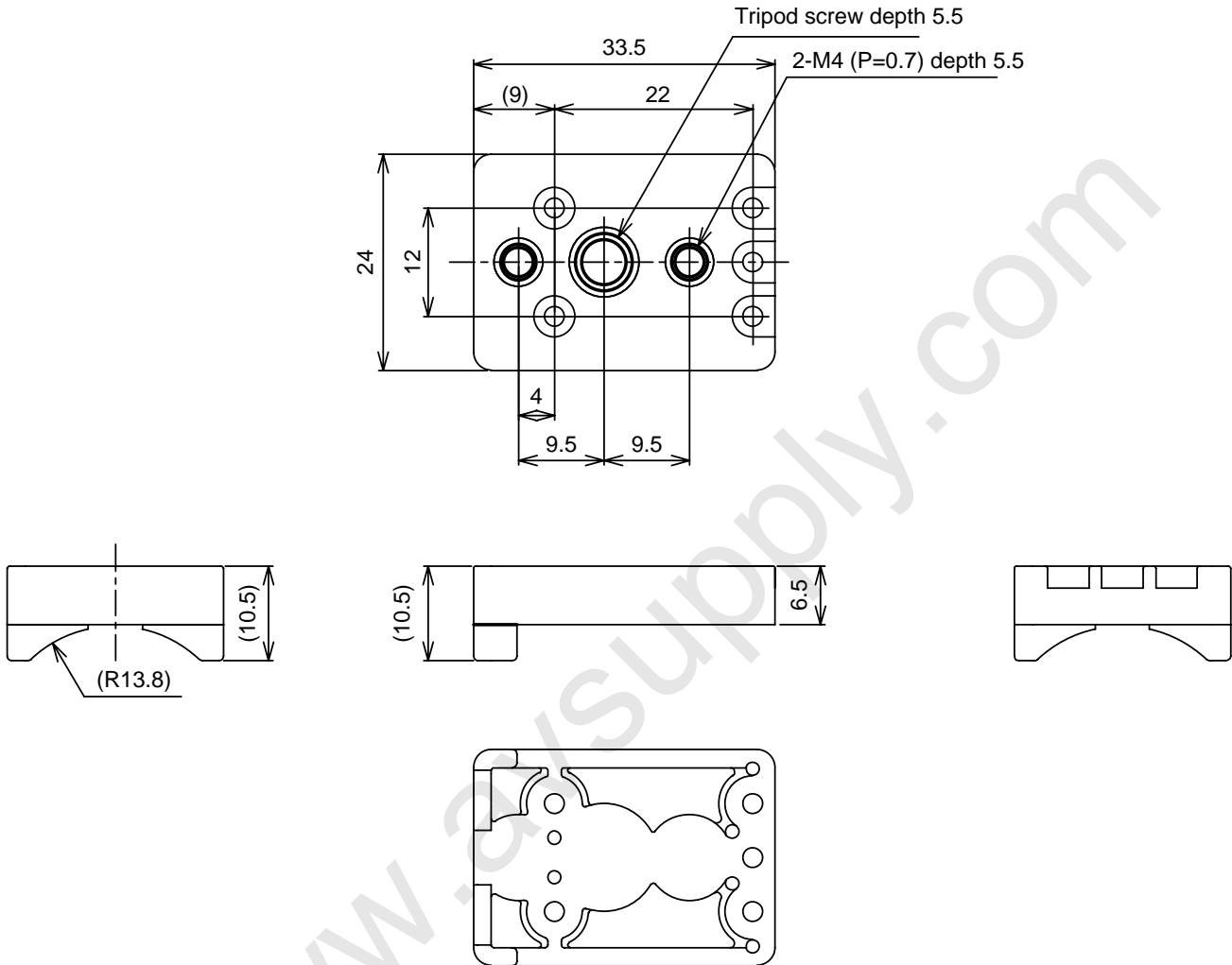

Unit: mm

Distributed By: Audio Video Supply -- Tel: 1-800-284-2288 -- www.avsupply.com

C. Dimensions (Camera with Tripod)

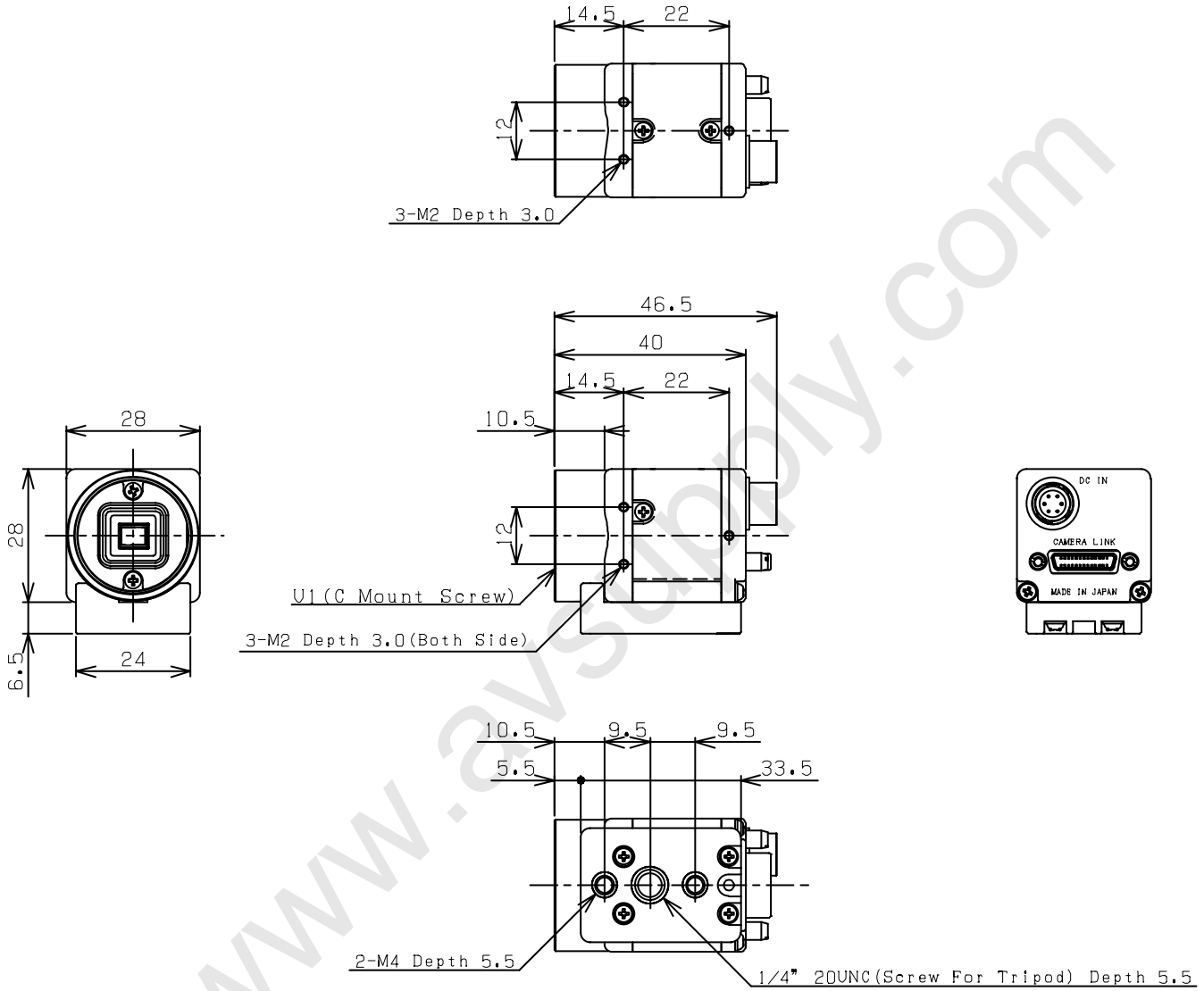

Unit: mm

Revisions

Revision	Date (D/M/Y)	Changes	Notes
1.0	19/06/2006	Created Document	
1.1	16/04/2007	Update 1) Mechanical Specs (optical center accuracy) 2) Communication Specs (Add the initial data and the data range)	
2.0	16/04/2008	Separate document from "Specification" to "Specifiaction" and "User's Guide"	
2.1	12/05/2008	Update 1) Connector specifications (Change the descriptions) 2) Electronic specifications (Change to "Active picture elements")	V2.1 through 2.6 was submitted by STJ all at once on Sept 9, 2009.
2.2	9/12/2008	Update 1) Pin assignment (Add the voltage range)	
2.3	17/3/2009	Update 1) Electronic specification (Change the shutter speed)	
2.4	23/4/2009	Update 1) Pin assignment (Add the connector drawing)	
2.5	8/5/2009	Update 1) Electronic specifications (Change the minimum illumination)	
2.6	18/8/2009	Update 1) Electronic specifications (Change S/N ratio (standard deviation)) 2) Mechanical specifications (Change description of the dimensions) 3) Change the page number	
2.7	14/7/2010	Update 1) Electronic specifications (Delete Effective Picture Element) 2) Connector specifications (Change "Interface connector" to Power/IO connector)	
2.8	12/7/2011	Update 1) Add the spectral sensitivity characteristics	

www.avsupply.com

Distributed By: Audio Video Supply -- Tel: 1-800-284-2288 -- www.avsupply.com

Sensor Technologies America, Inc.

1345 Valwood Pkwy, Suite 320
Carrollton, Texas 75006-6891
TEL (972) 481-9223 FAX (972) 481-9209
URL <http://www.sentechamerica.com/>

Sensor Technology Co., Ltd.

7F, Harada Center Building
9-17, Naka cho 4chrome
Atsugi-city, Kanagawa
243-0018 Japan
TEL +81-46-295-7061 FAX +81-46-295-7066
URL <http://www.sentech.co.jp/>

Taiwan Sensor Technology, Inc.

3F-6, No. 9, Aiguo W, Rd., Jhong Jheng District
Taipei City 100, Taiwan, R.O.C.
TEL 886-2-2383-2331 FAX 886-2-2370-8775
EMAIL: sentech0501@yahoo.com.tw