

# ULISSE NETCAM

## OUTDOOR FULL IP PTZ UNIT FOR NETWORK CAMERAS FOR HIGHEST PRECISION DAY/NIGHT MONITORING



### MAIN FEATURES

For Network cameras compatible with ONVIF protocol, Profile S, or equipped with RS485 serial port

Direct access to camera web pages via VT Tunneling

Variable speed: 0.02°-100°/s Pan; 0.02°-40°/s Tilt

Variable speed with UPTIRN LED illuminators: Pan 0.02°-40°/s - Tilt 0.02°-30°/s

Horizontal continuous rotation, vertical +90°/-40°

Housing for compact lenses

IP66

Autopan, Preset, Patrol

Position accuracy: 0.02°

Up to 250 Presets

Operating temperature: -20°C / +60°C (-4°F / +140°F)

Power supply available 230Vac, 24Vac or 120Vac

### OPTIONS:

Germanium window for thermal cameras

Prearrangement for mounting of two UPTIRN LED illuminators

Cold pack for low temperature down to -30°C (-22°F)

Wiper

### DESCRIPTION

ULISSE NETCAM is a powerful Full-IP PTZ for outdoor IP video surveillance, which can manage modern IP SD, HD and Megapixel cameras, with integration in a network system.

ULISSE NETCAM ensures maximum surveillance coverage in all outdoor environments, even the most difficult. It can operate 24 hours a day in demanding security applications, without requiring maintenance work.

This model can contain cameras with compact lenses.

A special feature of ULISSE NETCAM is the ability to easily control, via the network, all the camera's pan & tilt functions, including wiper, preset and set-up, using the most common VMS on the market. It is possible to use any ONVIF compatible Profile S camera, or proprietary protocol on RS-485, whilst the entire management of the system only requires an IP address.

The accurate top-mount construction ensures vision beyond the horizon and the continuous rotation on the horizontal axis, combining high speed to absolute tracking accuracy, both in manual mode and in patrol mode.

The unit can be equipped with a wiper for removing rain and dust from the front glass; there is a wide selection of jerry cans with washer pump, different capacities and heads.

To ensure detailed images even during the night hours, versions are available with LED illuminators, with infrared light or white light.

Optimal operation is ensured in very hot environments up to 60°C or in very cold environments up to -30°, thanks to optional enhanced heating.

Models are available for vision with a thermal camera.



ULISSE NETCAM



ULISSE NETCAM + 2 UPTIRN



ULISSE NETCAM FOR THERMAL CAMERAS

Specifications subject to change without notice. © Videotec S.p.A. All rights reserved.

**TECHNICAL DATA****GENERAL**

Built in aluminium and ABS  
 Epoxypolyester powder painting, RAL9002 colour  
 Top mount (OTT)  
 Transmission through toothed belt  
 Slip-ring  
 Electronic limit switches  
 Plug installation thanks to connector and easy replacement on-site  
 Zero backlash  
 Configuration of telemetry protocol parameters through dip-switch for RS485

**MECHANICAL**

Cable glands: 3xM16  
 Horizontal rotation: continuous  
 Vertical rotation: +90° to -40°  
 Horizontal speed (variable): from 0.02°/s up to 100°/s (from 0.02°/s up to 40°/s, with LED illuminators)  
 Tilt speed (variable): from 0.02°/s up to 40°/s (from 0.02°/s up to 30°/s, with LED illuminators)  
 Internal usable area: See drawings  
 Enclosure glass window (WxH): 118x75mm (4.6x2.7in)  
 Preset accuracy: 0.02°  
 Unit weight: 16.3kg (36lb) (16.8kg (37lb), with LED illuminators bracket)  
 ULISSE NETCAM, for thermal cameras:  
 Germanium window
 

- Dimensions (Ø): 70mm (2.8in) (external), 55mm (2.1in) (internal)
- Thick: 2mm (0.07in)
- External scratch-resistant treatment: Hard Carbon Coating (DLC)
- Internal antireflection treatment
- Spectral range: 7.5µm ÷ 14µm
- Medium transmittance (7.5µm ÷ 11.5µm): 94%
- Medium transmittance (11.5µm ÷ 14µm): 90%

**ELECTRICAL**

Suitable for use with network cameras  
 Input voltage:
 

- 230Vac, 50/60Hz, 100W
- 24Vac, 50/60Hz, 100W (150-190W max, with LED illuminators)
- 120Vac, 50/60Hz, 100W

 Current consumption:
 

- 230Vac, 0.4A
- 24Vac, 4A (8A, with LED illuminators)
- 120Vac, 0.8A

 Camera power supply: 12Vdc (800mA)  
 4 self-powered alarm inputs  
 2 dry contacts: 30Vdc max or 30Vac, @ 1A

**COMMUNICATIONS**

Ethernet connection: IEEE 802.3 100Base-Tx

**PROTOCOLS**

ONVIF, Profile S

**ENVIRONMENT**

Indoor/Outdoor  
 Operating temperature (with heater): -20°C (-4°F)/+60°C (140°F)  
 Operating temperature (with reinforced heater): -30°C (-22°F)/+60°C (140°F)  
 Wind resistance (without LED illuminators):
 

- Operational: up to 160km/h
- Stationary: up to 210km/h

 Resistant to salty fog (EN50130-5, EN60068-2-52)  
 Surge immunity: up to 2kV line to line, up to 4kV line to earth (Class 4)

**CERTIFICATIONS**

CE: EN60950-1, EN60950-22, EN61000-6-4, EN55022 Class A, EN50130-4  
 IP66 EN60529  
 cULus Listed, TYPE 4X (not for thermal cameras version)

**ACCESSORIES**

UPTIRN108A00	LED illuminator for ULISSE, 10°, 850nm, 24Vac - 12/24Vdc
UPTIRN308A00	LED illuminator for ULISSE, 30°, 850nm, 24Vac - 12/24Vdc
UPTIRN608A00	LED illuminator for ULISSE, 60°, 850nm, 24Vac - 12/24Vdc
UPTIRN109A00	LED illuminator for ULISSE, 10°, 940nm, 24Vac - 12/24Vdc
UPTIRN309A00	LED illuminator for ULISSE, 30°, 940nm, 24Vac - 12/24Vdc
UPTIRN10WA00	LED illuminator for ULISSE, 10°, white light, 24Vac - 12/24Vdc
UPTIRN30WA00	LED illuminator for ULISSE, 30°, white light, 24Vac - 12/24Vdc
UPTIRN60WA00	LED illuminator for ULISSE, 60°, white light, 24Vac - 12/24Vdc
UPTIRPS230	External power supply for ULISSE and ULISSE PLUS, prearranged for two LED illuminators, and control to synchronize IR illuminators with camera Day/Night switching, IN 230Vac, in weatherproof box. Twilight sensor included.
UPTIRPS120	External power supply for ULISSE and ULISSE PLUS, prearranged for two LED illuminators, and control to synchronize IR illuminators with camera Day/Night switching, IN 120Vac, in weatherproof box. Twilight sensor included.
UPTJBUL	Junction weatherproof box for cables connexion (according UL norm)
UPTHT1	Cold pack for low temperature 24Vac, 30W
WASPTOV5L5M00	Water tank 5l, pump with delivery up to 5m (16ft), IN 230Vac-24Vac-120Vac
WASPTOV23L5M00	Water tank 23l, pump with delivery up to 5m (16ft), IN 230Vac-24Vac-120Vac
WASPTOV23L11M00	Water tank 23l, pump with delivery up to 11m (36ft), IN 230Vac-24Vac-120Vac
WASPT1V23L30M00	Water tank 23l, pump with delivery up to 30m (98ft) with water floating, IN 230Vac
WASPT3V23L30M00	Water tank 23l, pump with delivery up to 30m (98ft) with water floating, IN 120Vac

**BRACKETS AND ADAPTORS**

UPTWBA	Wall bracket with internal cable channel
UPTWBTAB	Parapet bracket with internal cable channel
PTCC1	Pole mount adaptor
WCWGC	Corner mount adaptor

**PACKAGE**

Model Number	Weight	Dimensions (WxHxL)	Master carton
UPT1SVSAN00E	19.5kg (43lb)	66x33x57cm (26x13x22in)	-
UPT1SVWAN00E	20kg (44lb)	66x33x57cm (26x13x22in)	-
UPT2SVJAN00E	19.5kg (43lb)	66x33x57cm (26x13x22in)	-

ULISSE NETCAM - CONFIGURATION OPTIONS											
	Voltage			Options			Video output				
<b>UPT</b>	<b>1</b>	230Vac	<b>S</b>	Without camera	<b>V</b>	<b>S</b>	Without accessories	<b>A</b>	<b>N</b>	For Network cameras compatible with ONVIF protocol, Profile S, or with built-in telemetry output	<b>OOE</b>
	<b>2</b>	24Vac				<b>W</b>	With wiper				
	<b>3</b>	120Vac				<b>K</b>	With brackets for UPTIRN (only 24Vac, illuminators not included)				
						<b>J</b>	With wiper and brackets for UPTIRN (only 24Vac, illuminators not included)				
						<b>G</b>	With germanium front window for thermal cameras applications				

**TECHNICAL DRAWINGS**

Sizes in millimeters.

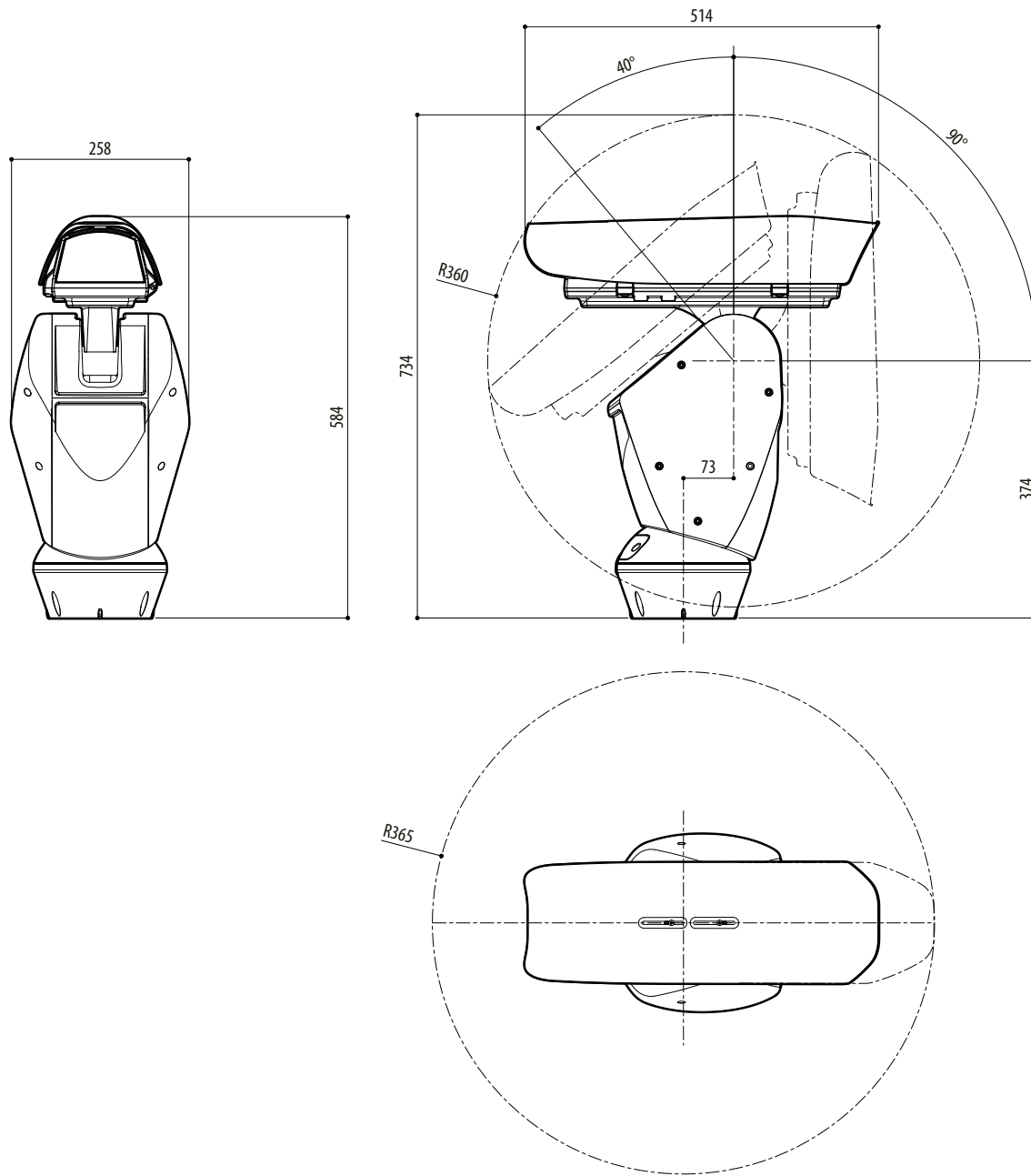

ULISSE NETCAM

Sizes in millimeters.

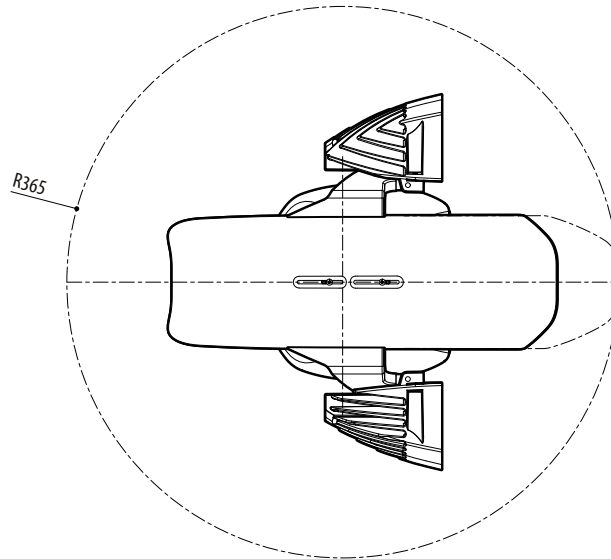
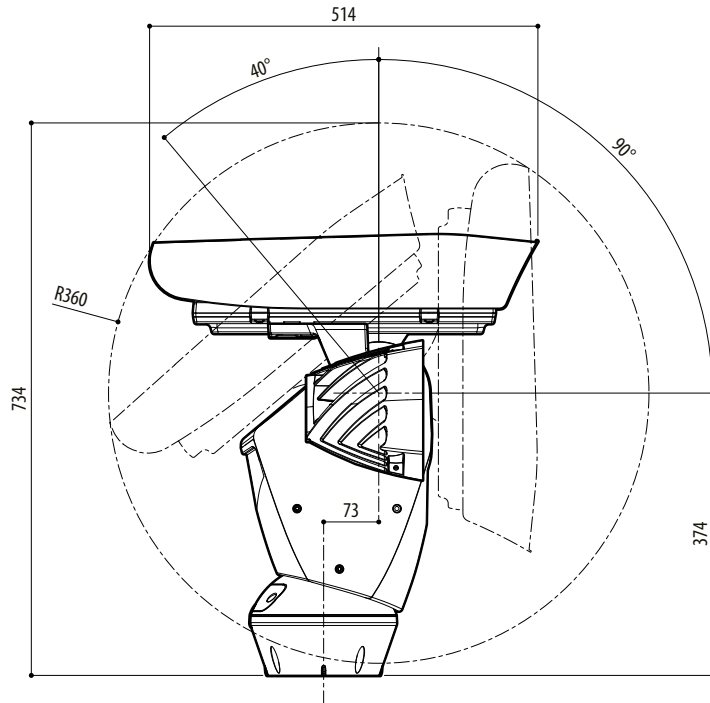
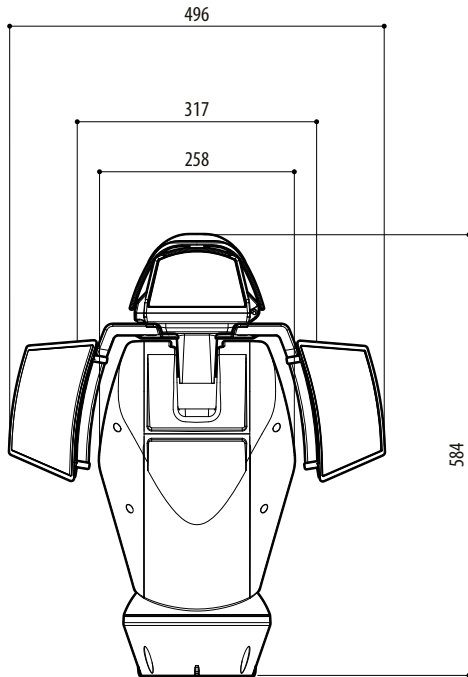

ULISSE NETCAM, PRE-ARRANGED VERSION FOR TWO LED ILLUMINATORS INSTALLATION

Sizes in millimeters.

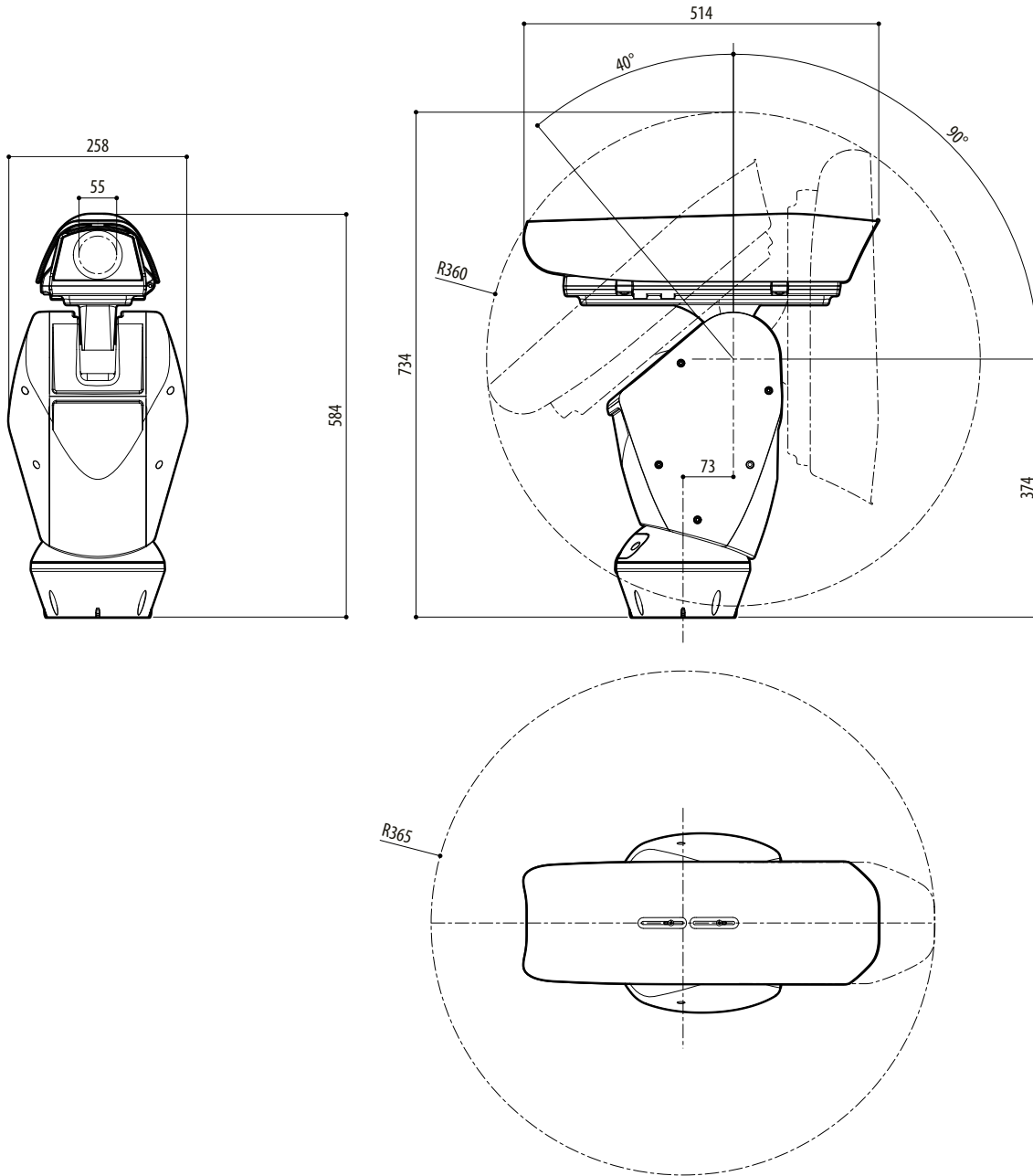

ULISSE NETCAM, VERSION FOR THERMAL CAMERAS

Sizes in millimeters.

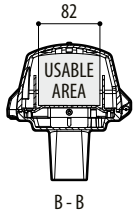
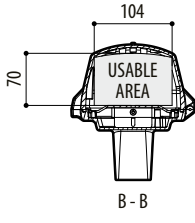
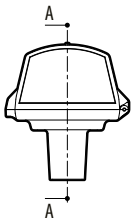

SLIDE IN STANDARD POSITION

SLIDE IN STANDARD POSITION, REINFORCED HEATER

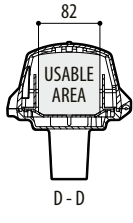
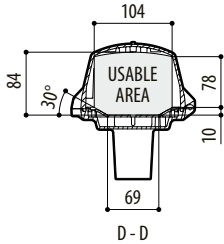
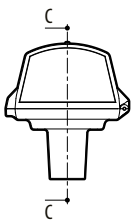
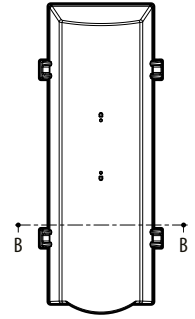
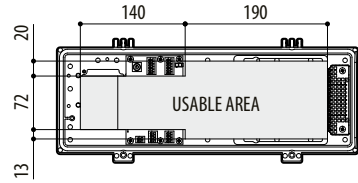
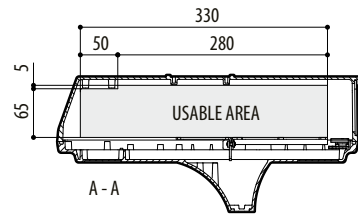

REVERSED SLIDE

SLIDE IN REVERSED SLIDE, REINFORCED HEATER

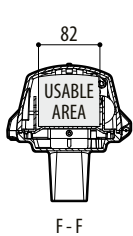
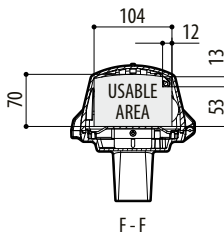
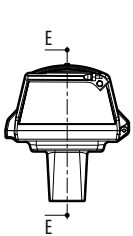
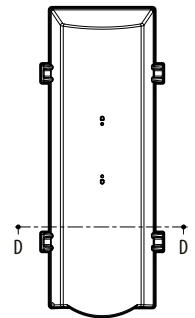
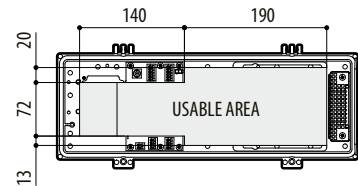
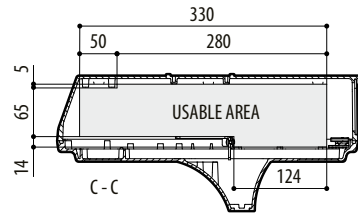

SLIDE IN STANDARD POSITION, INTEGRATED WIPER

SLIDE IN STANDARD POSITION, INTEGRATED WIPER, REINFORCED HEATER

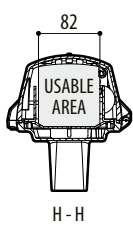
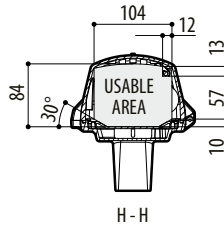
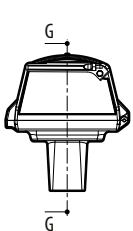
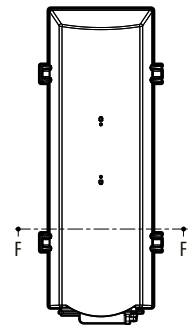
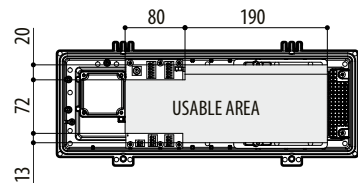
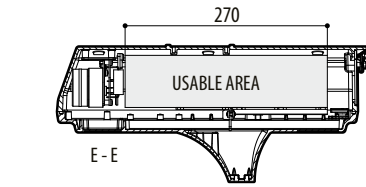

REVERSED SLIDE, INTEGRATED WIPER

REVERSED SLIDE, INTEGRATED WIPER, REINFORCED HEATER

