

Digital Day & Night Vandal Resistant Dome Camera

WDD-2977VDN



- 1/3" SONY super HAD CCD
- High resolution of 600TV lines
- User friendly OSD menu control (internal / external)
- Vari-focal 2.8-11mm auto IRIS lens (other vari-focal auto IRIS lenses available)
- 14 Infra-red illuminators provide scene illumination up to 30' distance
- Vandal resistant & weatherproof dome camera (IP66)
- DNR (digital noise reduction)
- Privacy function
- Additional functions (sens-up, motion detection, mirror, sharpness, sync-INT/LL)
- Elegant design

Distributed By: Audio Video Supply -- Tel: 1-800-284-2288 -- www.avsupply.com

SPECIFICATION

Power source & operating current	AC & DC dual power AC24V 180mA / DC12V 450mA	DC only DC12V 220mA
Power source tolerance	DC12V (tolerance:10V ~ 15V) / AC24V (tolerance:19.6V ~ 28.8V) regulated power input	
Total pixels	NTSC: 811(H) x 508(V) / PAL: 795(H) x 596(V)	
Effective pixels	NTSC: 768(H) x 494(V) / PAL: 795(H) x 596(V)	
Scanning system	600TV lines - 2:1 interlaced	
Synchronization	INT / LL selectable 0 ~ 359° (adjustable)	INT X
Frequency	NTSC (Horizontal: 15.734KHz / Vertical: 59.94Hz) PAL (Horizontal: 15.625KHz / Vertical: 50.00Hz)	
H. resolution	600TV line	
Video output level	1.0Vp-p/75 NTSC: video 0.714Vp-p sync 0.286Vp-p / PAL: video 0.7Vp-p sync 0.3Vp-p)	
S/N ratio (Y signal)	More than 50dB (AGC off)	
Min. illumination	0.3 Lux / F1.2 (color), 0.1 Lux / F1.2 (B/W), 0.002 Lux (sens-up), 0 Lux (IR LED on)	
color	On / auto	
Gain control	Off / low / middle / high	
White balance	AWT / AWC / manual / 1800°K / 10,500°K	
Shutter speed	Auto / manual (NTSC: 1/60, 1/120,000sec, PAL: 1/50, 1/120,000sec)	
Sens-up	Off / auto	
OSD	Built-in & external touch control (option)	
Motion detection	On / off (4 programmable zone)	
DNR	Off / low / middle / high (noise reduction)	
Mirror	Built-in (horizontal image inversion)	
Privacy function	On / off (4 programmable zone)	
Lens	Standard	Vari-focal 2.8-11mm auto DC IRIS day & night lens (STD)
	Option	X
IR LED visibility range	Standard	Visible 5mm diameter (850nm ±20°) 14EA / real (approx. 30 Feet)
	Option	Visible 5mm diameter (850nm ±20°) 14EA / real (approx. 30 Feet)
CDS sensor (approx.)	IR LED On / off at 1-5 Lux	
Operating temperature / humidity	14°F ~ 122°F (-10°C ~ +50°C) / 10% ~ 95% RH	
Dimensions (WxHxD)	145mm x 100mm x 145mm (5.7" x 3.9" x 5.7")	
Weight (approx.)	420g / 0.92lbs (without stand type)	
Output cable (approx.)	4 feet cable with BNC female for video / DC jack-male or wire for power	
Extra video terminal	Pitch 2.0mm 2Pin wafer molex (Inside terminal NO:53014-0210 & outside terminal NO:53014-0210)	
Extra video check cable (approx.)	2 feet cable with BNC female for video (molex terminal housing NO:51004-2000)	

weldex.com
oem@weldex.com
Tel: (714) 761-2100 [USA]
Fax: (714) 761-3811 [USA]
Tel: +49 (0)2102 528 2803 [GER]
Fax: +49 (0)2102 528 2804 [GER]

For design help, accessories or pricing, please contact:
sales@avsupply or call: 1-858-565-1101

© 2014 Weldex
6751 Katella Avenue, Cypress, CA 90630 [USA]
Broichhof Strasse 5 D-40880 Ratingen, Germany [GER]



1-800-284-2288 sales@avsupply.com
www.avsupply.com

Digital High Res. Vandal Resistant Dome Camera

DIMENSIONS (Unit: mm)

WDD-2977VDN

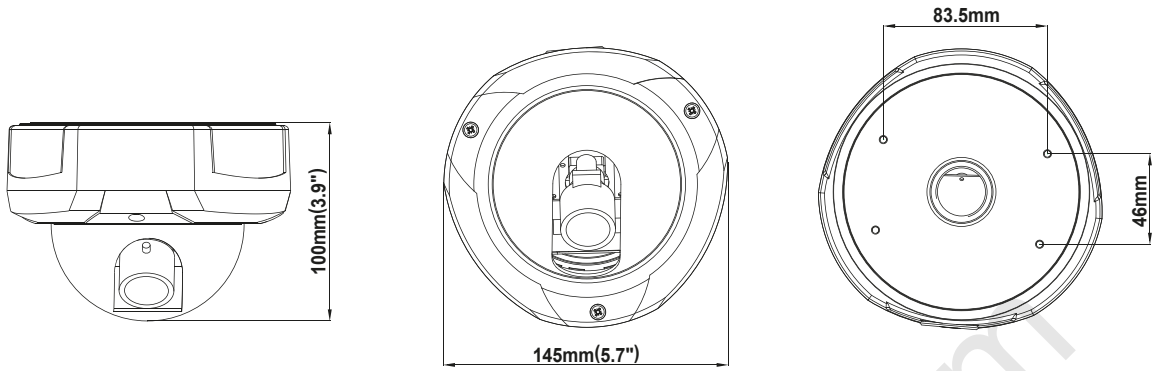

Distributed By: Audio Video Supply -- Tel: 1-800-284-2288 -- www.avsupply.com

weldex.com
oem@weldex.com
Tel: (714) 761-2100 [USA]
Fax: (714) 761-3811 [USA]
Tel: +49 (0)2102 528 2803 [GER]
Fax: +49 (0)2102 528 2804 [GER]

© 2014 Weldex
6751 Katella Avenue, Cypress, CA 90630 [USA]
Broichhof Strasse 5 D-40880 Ratingen, Germany [GER]

WELDEX

For design help, accessories or pricing, please contact:
sales@avsupply or call: 1-858-565-1101